



◆ WARNING

For safety reasons, this kit must be installed by an authorized Bombardier Ski-Doo snowmobile dealer. Should removal of a locking device be required when undergoing disassembly/assembly, always replace with a new one. This instruction sheet should be given to the purchaser after modification. This kit is designed for specific applicable models only. It is not recommended for snowmobiles other than those for which it was sold.

NOTE: Installation time is approximately 2.5 hours.

PARTS TO BE INSTALLED

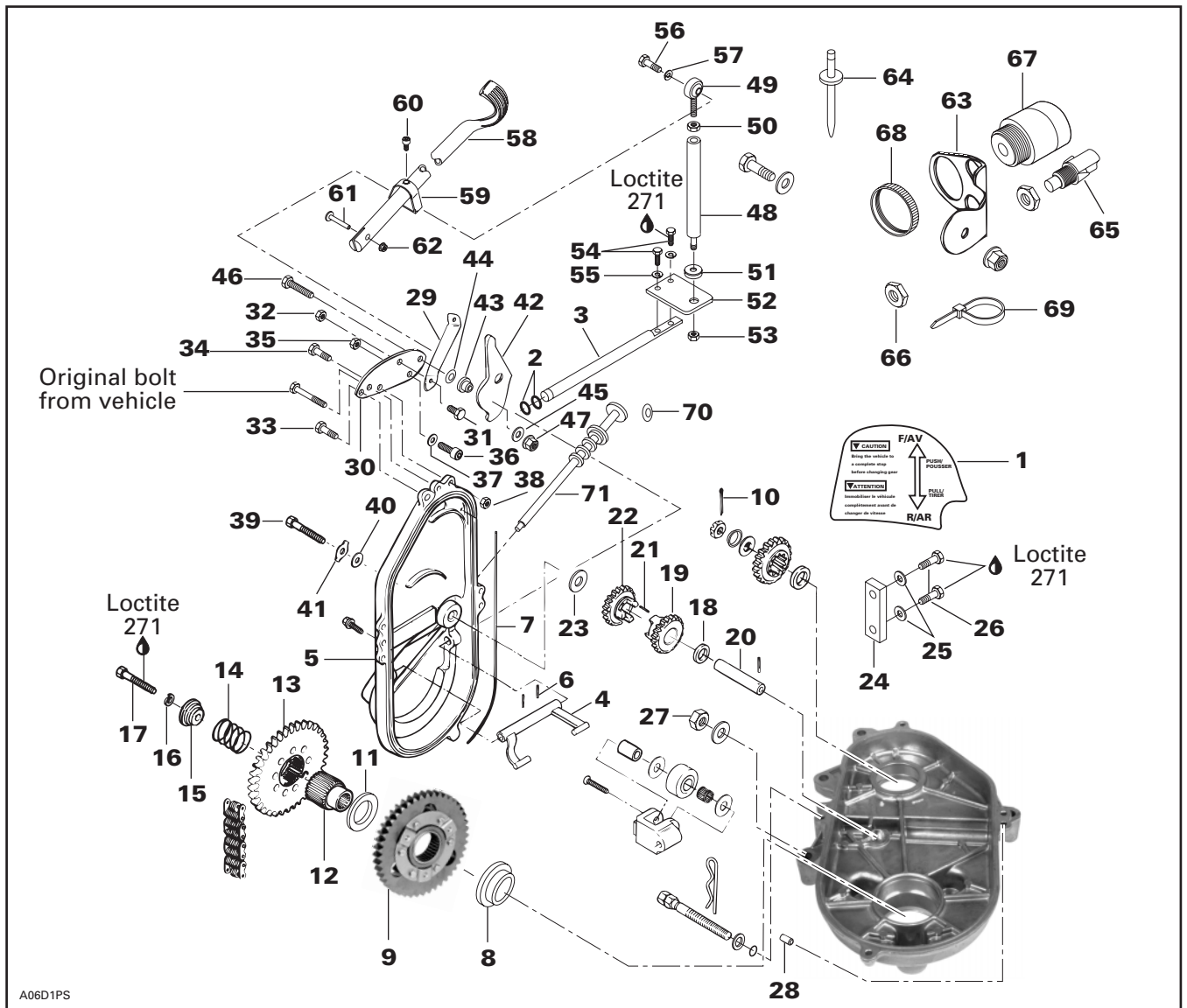

A06D1PS

1. Decal
2. O-ring, Viton (2)
3. Shaft
4. Fork
5. Chaincase Cover
6. Spring Pin (2)
7. O-ring
8. Retaining Ring
9. Lower Sprocket Assembly, 44 Tooth
10. Cotter Pin
11. Washer
12. Coupling Shaft
13. Sliding Gear
14. Release Spring
15. Cap
16. Lock Washer M10
17. Hex. Bolt M10 X 50
18. Ring
19. Drive Sprocket, 19 Tooth
20. Reverse Shaft Assembly
21. Rubber Alignment Rod
22. Reverse Gear, 19 Tooth
23. Spacer
24. Chain Slider
25. Copper Washer (2)
26. Hex. Bolt M6 X 16 (2)
27. Elastic Nut M10
28. Dowel Pin
29. Side Support
30. Pivot Support
31. Hex. Bolt M6 X 16
32. Elastic Nut M6
33. Self-Tapping Hex. Bolt M6 X 16
34. Hex. Bolt M6 X 20
35. Elastic Nut M6 (3)
36. Socket Screw M6 x 16
37. Washer M6
38. Elastic Nut M6
39. Hex. Bolt M8 X 90
40. Copper Washer M8
41. Locking Tab
42. Pivot Plate
43. Flange Bushing
44. O-ring
45. Washer M8
46. Hex. Bolt M8 X 35
47. Elastic Nut M8
48. Tie-Rod
49. Ball Joint
50. Tie-Rod Jam Nut M6
51. Rubber Washer
52. Tie-Rod Plate
53. Elastic Nut M5
54. Hex. Bolt M5 X 14 (2)
55. Lock Washer M5 (2)
56. Hex. Bolt M6 X 20
57. Lock Washer M6
58. Handle
59. Switch Stopper
60. Metal Screw
61. Steel Rivet 3/16
62. Push Nut 3/16
63. Backup Alarm Support
64. Pop Rivet (2)
65. Backup Alarm Switch
66. Switch Jam Nut
67. Backup Alarm
68. Plastic Nut
69. Locking Tie (2)
70. O-ring (2)
71. Filler Cap Assy.

INSTRUCTIONS

▼ CAUTION

Do not use a 20 tooth or a 24 tooth sprocket in conjunction with the 44 tooth sprocket

Console Preparation

1. Position template (found on the last page of these instruction sheets) on RH side of the console as illustrated below.
2. Drill a 17.5 mm (11/16 in) hole in the console using template's center lines as a guide.

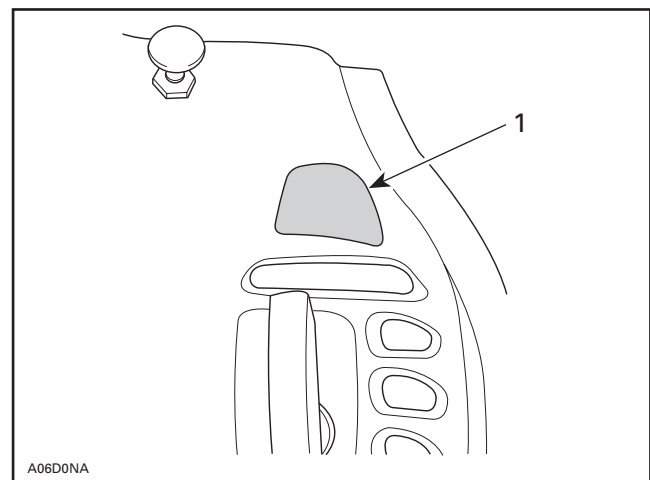

1. Template

- Using a portable propane torch, heat up the embossed section of the console until the plastic surface of the dash has a shiny appearance, i.e. a wet look.
- Apply decal **no. 1** on plastic surface.

Chaincase Preparation

- Remove tuned pipes and muffler.
- Remove tension from chain.
- Remove chaincase cover, sprockets and lower spacer.
- Discard lower sprocket, spacer, M10 bolt, lock washer, cap and chaincase cover.

Chaincase Cover

- Install O-rings **no. 2** on fork shaft **no. 3**. Apply multi-purpose grease on both O-rings and shaft.
- Position the fork **no. 4** in the new chaincase cover **no. 5**. Insert fork shaft through hole in new cover then slide shaft into fork. Secure with spring pins **no. 6**. Ensure to position flat surface of shaft lever upwards as illustrated.
- Install O-ring **no. 7** in cover.

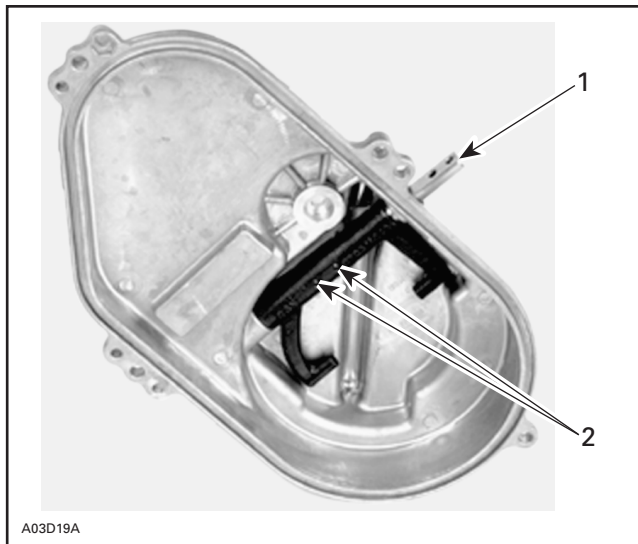

- Position notch toward the top
- Align holes

Chaincase

Remove and discard bolts and copper washers that are located close to the chain tensioner adjustment screw.

Finalizing Chaincase Assembly

- Install spacer **no. 8**, see following photo.
- Install the lower sprocket assembly **no. 9** over drive axle and properly mesh with chain.

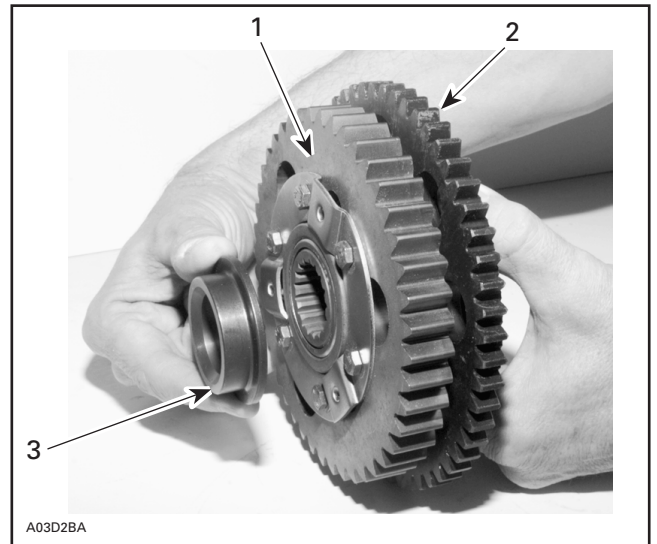

- 44 tooth gear
- 56 tooth gear
- Spacer

- Install upper sprocket, spacer and castellated nut. Torque nut to 68 N•m (50 lbf•ft). Secure the nut with a new cotter pin **no. 10**.
- Install washer **no. 11**, coupling shaft **no. 12**, sliding gear **no. 13**, release spring **no. 14**, cap **no. 15**, lock washer **no. 16** and bolt **no. 17**. Apply Loctite 271 (red) on bolt threads. Torque bolt to 48 N•m (35 lbf•ft).
- On reverse shaft **no. 20** install ring **no. 18** with drive sprocket **no. 19** making sure to properly position spring pin in housing slot. Install rubber alignment rod **no. 21** and reverse gear **no. 22**. Drive sprocket hole and reverse gear hole must be aligned to insert rubber alignment pin. Install thrust washer **no. 23**.

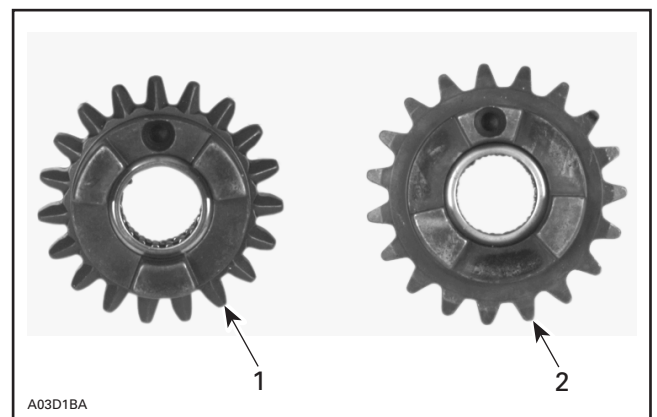

- Reverse sprocket (hole between dogs)
- Drive sprocket (hole on dog)

6. Install chain slider **no. 24** and position longitudinal chamfer against chaincase wall. Position copper washer **no. 25** against bolt **no. 26**. Apply Loctite 271 (red) on bolt threads, use sparingly. Torque bolt to 10 N•m (90 lbf•ft).

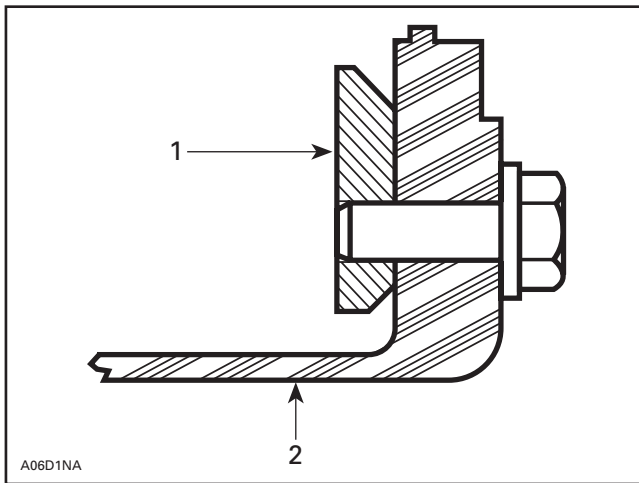

1. Chain slider
2. Chaincase side facing the chassis

7. Install new elastic nut **no. 27** and torque to 42 N•m (31 lbf•ft), if removed.
8. Fully tighten chain adjusting screw by hand, then back off only far enough for hair pin to engage in locking hole.
9. Install dowel pin **no. 28** and join chaincase cover to chaincase by passing fork tabs behind sliding sprocket lip.

▼ CAUTION

Chaincase cover must completely lay against chaincase.

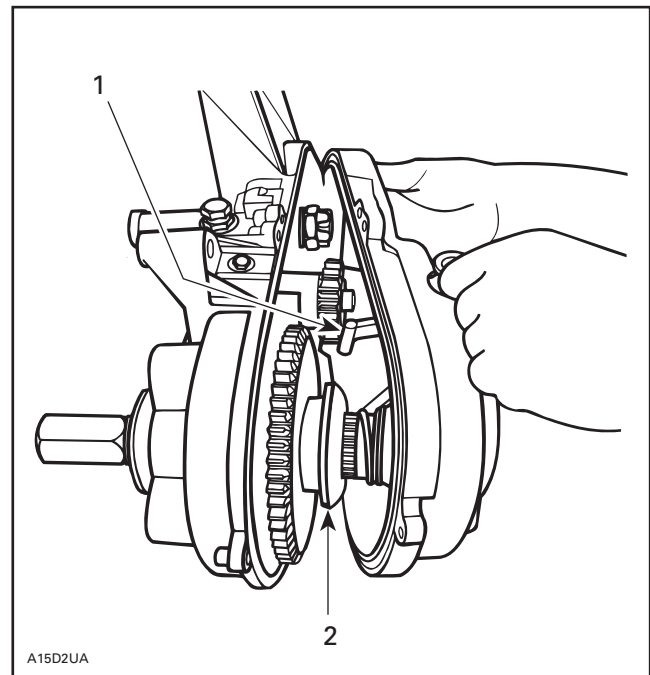

1. Fork tabs
2. Sliding sprocket lip

10. Remove existing bolt, from beneath the coolant reservoir, discard side support and save rubber spacer see photo.

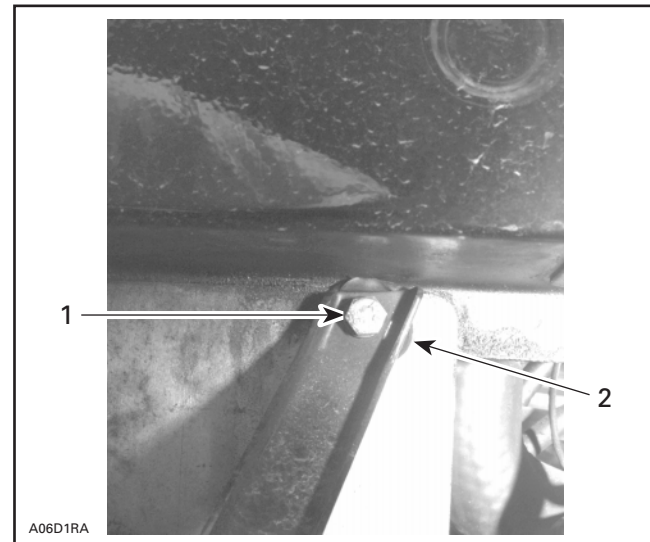

1. Remove bolt
2. Rubber spacer

11. Install side support **no. 29** on pivot support **no. 30** using bolt M6 X 16 **no. 31** and elastic nut **no. 35**. Install socket screw **no. 36** with washer **no. 37** and elastic nut **no. 35** on pivot support.

12. Bolt the side support **no.29** to oil tank support with original bolt and lock washer.

NOTE: Make sure to reinstall rubber spacer.

13. Install pivot support **no. 30** on chaincase with original bolt. Install self-tapping bolt M6 X 16 **no. 33** and bolt M6 X 20 **no. 34** with elastic nut **no. 38**.

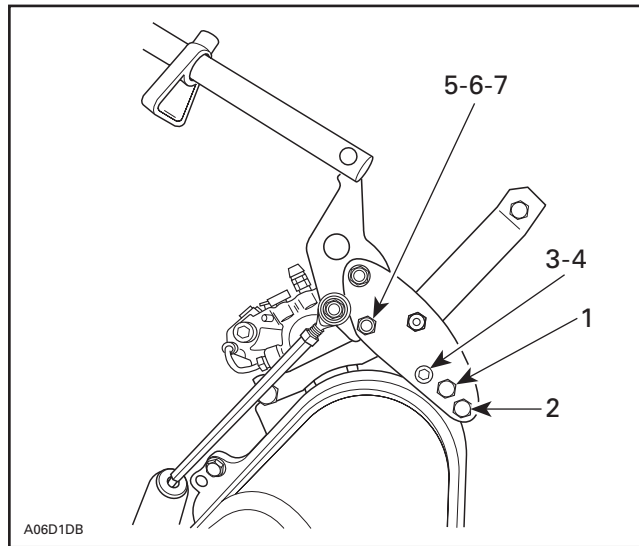

1. Existing bolt
2. Self-tapping bolt M6 x 16
3. Bolt M6 x 20
4. Elastic nut
5. Socket screw facing inward with bolt out
6. Washer
7. Elastic nut

14. Tighten chaincase bolts in a criss-cross sequence beginning with top center. Install reverse shaft bolt **no. 39** with copper washer **no. 40** against chaincase cover and locking tab **no. 41** against bolt head. Position angled end of tab to rear then torque bolt to 15 N•m (133 lbf•in). Bend locking tab against bolt head.

Shifting Linkage Assembly

1. Install pivot plate **no. 42** on pivot support **no. 30** with flanged bushing **no. 43**, O-ring **no. 44**, washer **no. 45**, bolt M8 **no. 46** and elastic nut M8 **no. 47**.

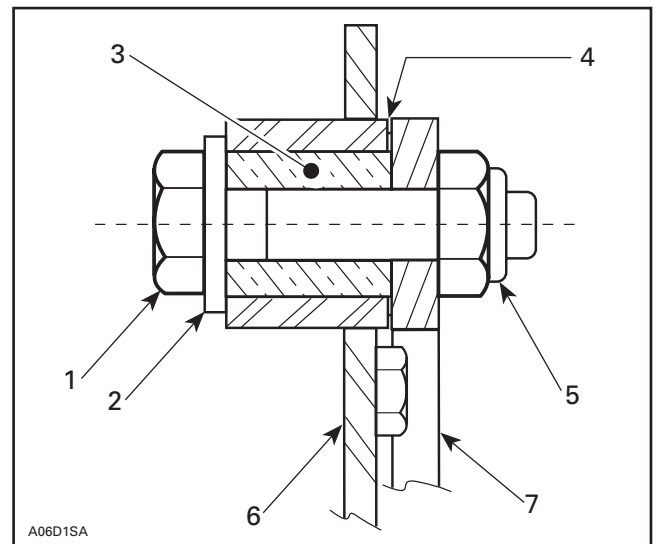

1. Hex bolt M8 x 35 **no. 46**
2. Washer M8 **no. 45**
3. Bushing **no. 43**
4. O-ring **no. 44**
5. Elastic nut M8 **no. 47**
6. Pivot plate **no. 42**
7. Pivot support **no. 30**

2. Install the ball joint **no. 49** with jam nut **no. 50**, on one end of the tie-rod **no. 48** then on the other, install rubber washer **no. 51**, with metal side facing upward, tie-rod plate **no. 52** with its offset towards the rear and secure with elastic nut **no. 53**. Tighten nut.
3. Secure the plate on shaft **no. 53** with bolts **no. 54** and lock washers **no. 55**. Apply Loctite 242 (blue), use sparingly.
4. Install ball joint on swivel plate with bolt **no. 56** and lock washer **no. 57**.

Handle Installation

1. Insert handle **no. 58** through hole in console. Slide switch stopper **no. 59** over handle then secure with metal screw **no. 60**. Do not tighten screw yet. Connect handle extremity to pivot plate and secure with steel rivet **no. 61** and push nut **no. 62**.

Backup Alarm Installation

1. Drill two 5.2 mm (7/32 in) holes in oil tank support as illustrated. Holes may already be drilled.

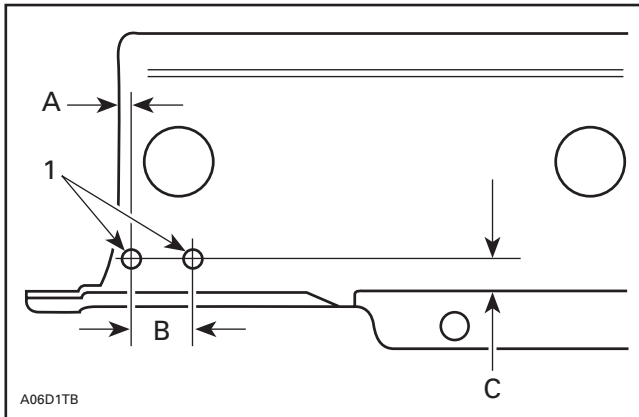

1. Drill here
- A. 4 mm (5/32 in)
- B. 21 mm (13/16 in)
- C. 11 mm (7/16 in)

2. Install the backup alarm support **no. 63** with the pop rivets **no. 64**.
3. Install backup alarm switch **no. 65** on backup alarm support **no. 63** and secure with jam nut **no. 66**. Install backup alarm **no. 67** on same support **no. 63** and secure with plastic nut **no. 68**.
4. Connect terminals to alarm, make sure that the RED/BLUE wire is connected to the alarm's negative post. Connect tab connector housing to vehicle harness. Secure wiring harness to support using a locking tie **no. 69**.

ADJUSTMENTS

1. Check proper fit of handle in console.
2. Shift into reverse gear.

NOTE: If it is impossible to shift into reverse gear, shorten tie-rod and try again. Turn the brake disk to free the gears. If it is still impossible, check if the fork engages in the sliding gear or disassemble to inspect components.

3. Completely slacken tie-rod jam nut **no. 50** on the gear shift linkage.
4. Using tool (P/N 529 0303 00) to push and hold down the tie-rod plate to make sure transmission is in reverse gear. Pull shifter handle in reverse position making sure all slack is removed. Lengthen tie-rod until it contacts the rubber washer then add an additional turn.

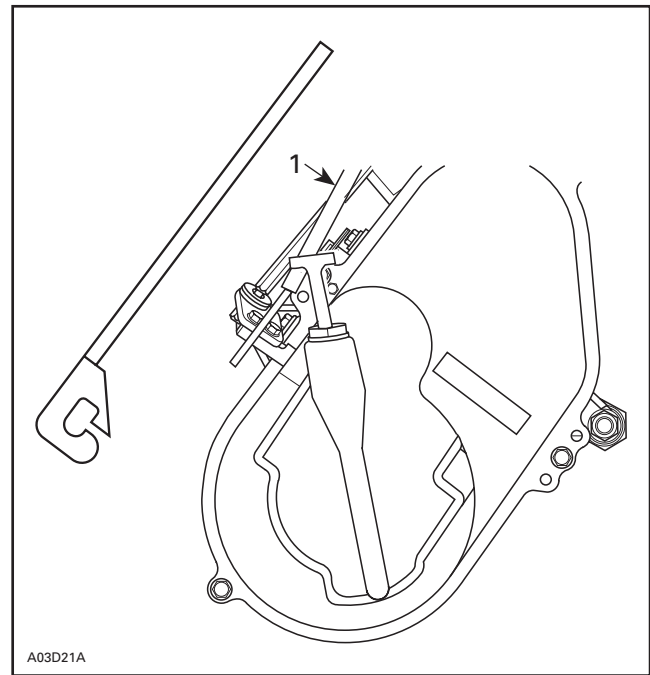

1. Tool

NOTE: It is normal to feel a light friction when shifting into gear.

5. Statically test transmission operation in forward and reverse positions.
6. Hold linkage and tighten tie-rod jam nut **no. 50**.
7. Adjust backup alarm so that it beeps when transmission is in reverse gear while engine is running.

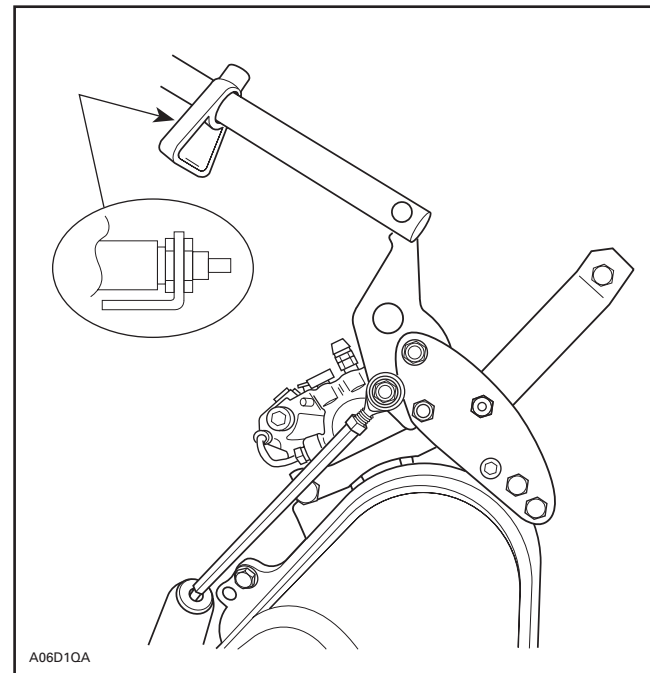

Filling With Oil

1. Fill chaincase with synthetic chaincase oil (P/N 413 8033 00). Oil capacity is approximately 250 mL (8 oz).
2. Apply oil to O-rings **no. 70** then install on the new dipstick **no. 71**.
3. Check oil level with dipstick, oil level must be between the marks.

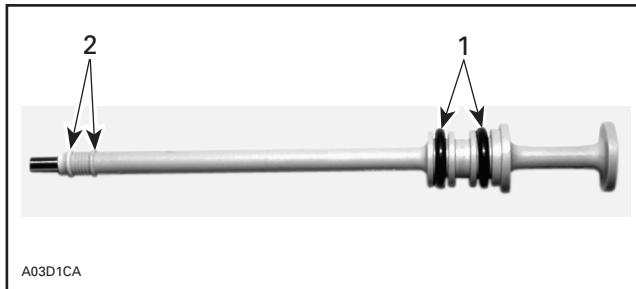

1. O-rings
2. Oil level marks



1. Dipstick
4. Reinstall tuned pipes and muffler.
5. Test drive transmission operation.

THIS PAGE IS PURPOSELY BLANK

TEMPLATE FOR DRILLING SHIFTER ARM HOLE IN CONSOLE

1. Cut template all around.
2. Position and stick template on RH side of console, centered over heated plastic surface. Drill a 17.5 mm (11/16 in) hole in console using template center lines as a guide.

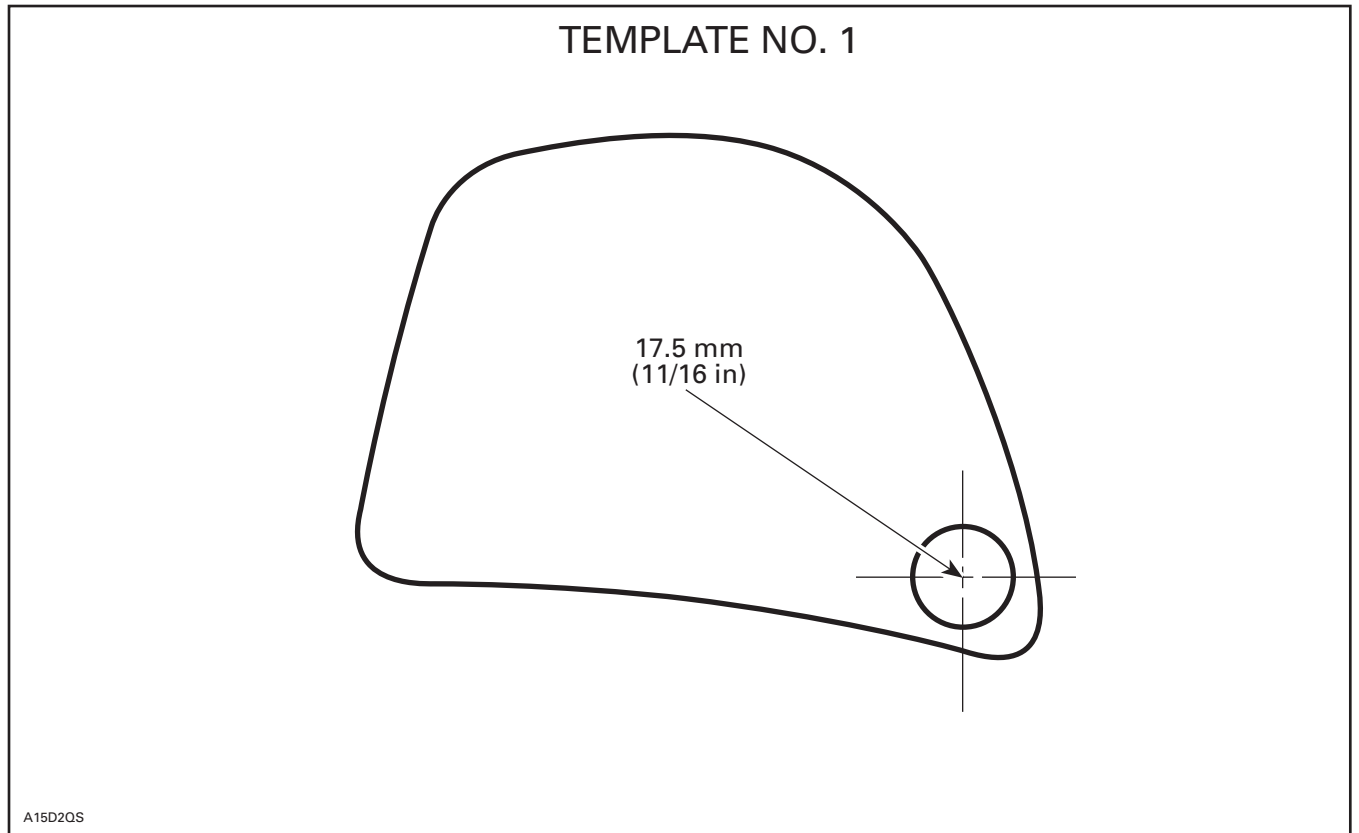

860 4231 00

1.	414 9622 00	Decal	Autocollant
2.	414 7732 00	O-ring, Viton (2)	Joint torique en viton (2)
3.	504 1429 00	Shaft	Arbre
4.	504 0758 00	Fork	Fourchette
5.	504 0985 00	Chaincase Cover	Couvercle du carter de chaîne
6.	414 7725 00	Spring Pin (2)	Goupille ressort (2)
7.	414 3623 00	O-ring	Joint torique
8.	504 0763 00	Retaining Ring	Anneau de retenue
9.	581 0968 00	Lower Sprocket Assembly, 44 Tooth	Pignon inférieur complet, (44 dents)
10.	371 8013 00	Cotter Pin	Goupille fendue
11.	504 0943 00	Washer	Rondelle
12.	504 0977 00	Coupling Shaft	Arbre d'accouplement
13.	504 0968 00	Sliding Gear	Pignon coulissant
14.	504 0992 00	Release Spring	Ressort de rappel
15.	504 0991 00	Cap	Capuchon
16.	224 7011 88	Lock Washer M10	Rondelle-frein M10
17.	222 0050 65	Hex. Bolt M10 x 50	Boulon hexagonal M10 x 50
18.	504 0787 00	Ring	Bague
19.	581 0969 00	Drive Sprocket, 19 Tooth	Pignon d'entraînement (19 dents)
20.	580 5906 00	Reverse Shaft Assembly	Arbre de marche arrière (complet)
21.	570 0486 00	Rubber Alignment Rod	Tige d'alignement de caoutchouc
22.	581 1222 00	Reverse Gear, 19 Tooth	Pignon de marche arrière (19 dents)
23.	504 0773 00	Spacer	Entretoise
24.	504 0824 00	Chain Slider	Coulisseau de chaîne
25.	732 9000 40	Copper Washer (2)	Rondelle de cuivre (2)
26.	222 0616 65	Hex. Bolt M6 X 16 (2)	Boulon hexagonal M6 X 16 (2)
27.	228 5010 45	Elastic Nut M10	Écrou d'arrêt élastique M10
28.	732 6200 01	Dowel Pin	Goupille d'assemblage
29.	504 0989 00	Side Support	Support latéral
30.	504 0986 00	Pivot Support	Support de pivot
31.	222 0616 65	Hex. Bolt M6 x 16	Boulon hexagonal M6 x 16
32.	228 5610 45	Elastic Nut M6	Écrou d'arrêt élastique M6
33.	732 6000 02	Self-Tapping Hex. Bolt M6 x 16	Boulon autotaraudeur à tête hexagonale M6 x 16
34.	222 0620 65	Hex. Bolt M6 X 20	Boulon hexagonal M6 X 20
35.	228 5610 45	Elastic Nut M6 (3)	Écrou d'arrêt élastique M6 (3)
36.	222 9616 65	Socket Screw M6 x 16	Vis à tête creuse M6 x 16