

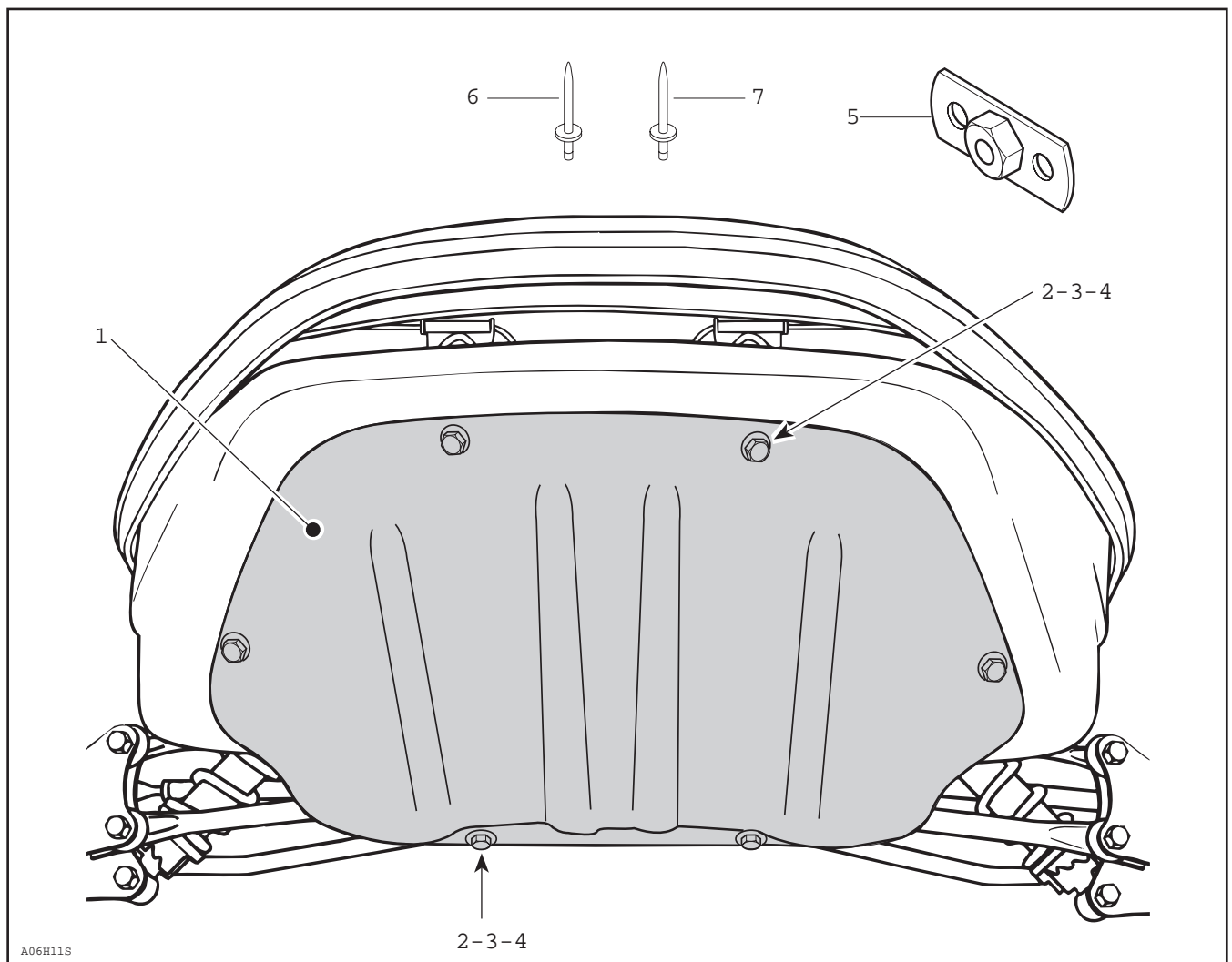

◆ **WARNING:** For safety reasons, this kit must be installed by an authorized Bombardier Ski-Doo snowmobile dealer. Should removal of a locking device be required when undergoing disassembly/assembly, always replace with a new one. This instruction sheet should be given to the purchaser after modification. This kit is designed for specific applicable models only. It is not recommended for snowmobiles other than those for which it was sold.

○ **NOTE :** Installation time is approximately 1.0 hour.

PARTS TO BE INSTALLED



- | | |
|------------------------|------------------------|
| 1. Skid Plate (Black) | 4. Flat Washer (6) |
| 1. Skid Plate (Yellow) | 5. Welded Plate (6) |
| 1. Skid Plate (Red) | 6. Pop Rivet (4) |
| 2. Hex Bolt M6 (6) | 7. Black Pop Rivet (8) |
| 3. Lock Washer (6) | |

INSTRUCTIONS

1. Remove tuned pipe(s).
2. Safely lift and hold front of vehicle to work under.
3. From beneath the front of the chassis drill two 8 mm (5/16 in) holes, see illustration.

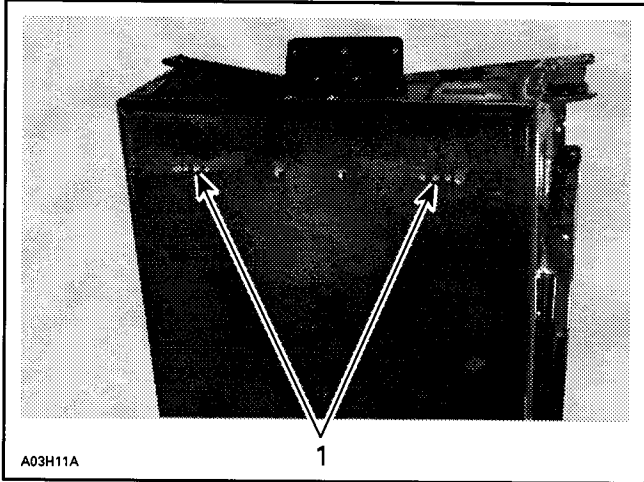

1. Drill here

4. Remaining under the chassis, drill four 5 mm (3/16 in) holes as shown in the following illustration.

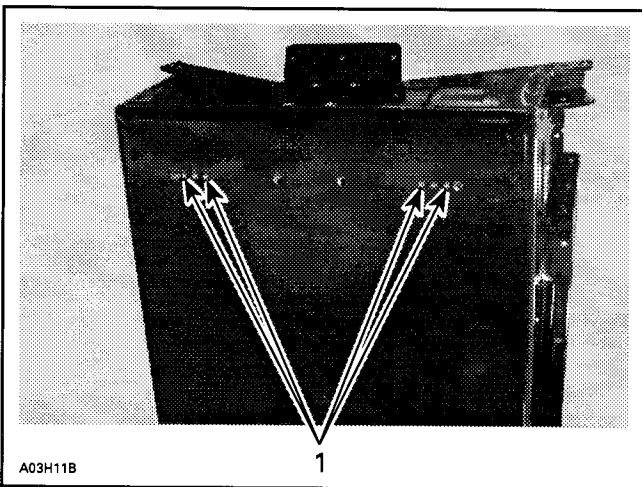

1. Drill here

5. Install two welded plates **no. 5** using pop rivets **no. 6**. Nut on welded plate must be facing upwards.
6. Temporarily install skid plate **no. 1** depending on color using two bolts **no. 2**, two lock washers **no. 3**, and two flat washers **no. 4**, then hand tighten.
7. Center the skid plate with the front bumper mount.

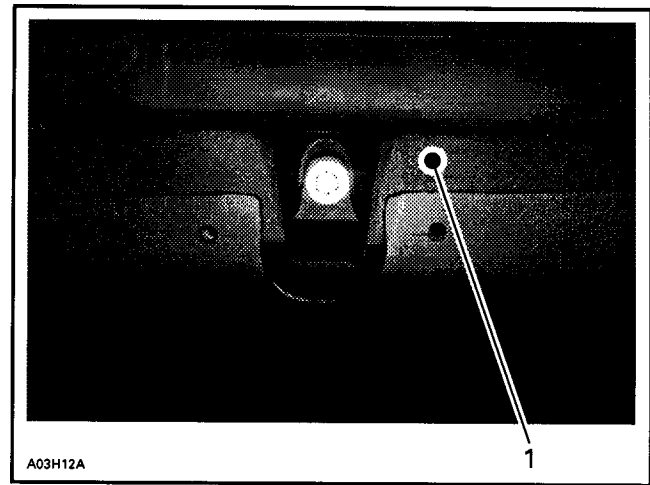

1. Front bumper mount

8. Push on the new skid plate from beneath to assure a tight fit, then using a punch, mark the four holes on the bottom pan.
9. Loosen the bolts that were previously installed and lower the skid plate.
10. Drill four 8 mm (5/16 in) holes in the bottom pan.

NOTE: For the following, use one of the bolts and one of the welded plates from this kit as a template.

11. From inside the engine compartment, insert the bolt through the previously drilled hole in the bottom pan and position the welded plate on the outer side. Position the plate so it is horizontal then hand tighten.

Drill two 5 mm (3/16 in) holes.

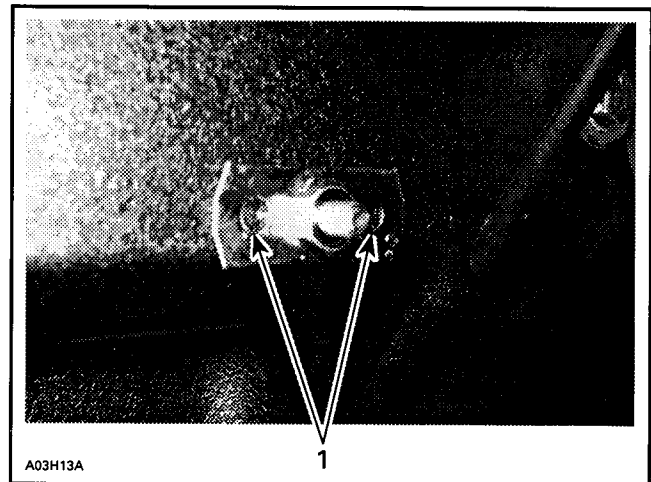

1. Drill here

Loosen the bolt and remove the plate.

Repeat this procedure 3 more times.

12. Install the welded plates **no. 5** from the inside of the engine compartment with the nuts on the plates facing inward.

13. Secure plates using black pop rivets **no. 7**.
14. Reposition the new skid plate by aligning the holes.
15. Install bolts **no. 2**, lock washers **no. 3** and flat washers **no. 4**.
16. Tighten all the bolts so that the new skid plate fits snug.
17. Reinstall tuned pipe(s).

861 7497 00
861 7498 00
861 7534 00

1.	572 0785 00	Skid Plate (Black)	Plaque protectrice (noire)
1.	572 0785 01	Skid Plate (Yellow)	Plaque protectrice (jaune)
1.	572 0785 02	Skid Plate (Red)	Plaque protectrice (rouge)
2.	222 0625 65	Hex Bolt M6 (6)	Boulon hexagonal M6 (6)
3.	224 7611 10	Lock Washer (6)	Rondelle-frein (6)
4.	224 0612 01	Flat Washer (6)	Rondelle plate (6)
5.	517 2698 00	Welded Plate (6)	Plaque soudée (6)
6.	390 4023 00	Pop Rivet (4)	Rivet (4)
7.	390 4096 00	Black Pop Rivet (8)	Rivet noir (8)