



CATALOGUE DE **PARTS**
PIECES CATALOG



SKI-DOO[®]

TUNDRA II LT

1996

480 1403 00

PARTS CATALOG CATALOGUE DE PIÈCES

1996

TUNDRA II LT

◆ WARNING : For user safety, Rotax engines designed for snowmobiles must not be used to power products other than Ski-Doo snowmobiles.

Bombardier Inc. and its subsidiaries denies any responsibility for any usage other than the one prescribed.

Dealers that do not follow this practice may be financially liable should injury occur.

Bombardier Inc. reserves the right at any time to discontinue or change specifications, designs, features, models or equipment without incurring obligation.

◆ AVERTISSEMENT : Pour la sécurité des utilisateurs, les moteurs Rotax conçus pour les motoneiges ne doivent pas être utilisés pour des fins autres que de faire fonctionner les motoneiges Ski-Doo.

Bombardier Inc. et ses filiales se dégagent de toute responsabilité pouvant découler des utilisations autres que celle prescrite.

Les concessionnaires qui ne se conforment pas à cet avis peuvent être tenus responsables financièrement advenant des blessures.

Bombardier Inc. se réserve le droit d'effectuer des changements dans le dessin et les caractéristiques de ses véhicules et / ou d'y effectuer des apports ou des améliorations, cela sans s'engager d'aucune façon à effectuer lesdites opérations sur les véhicules déjà fabriqués.

PARTS CATALOG

The illustrations figuring in this parts catalog show typical construction of the different assemblies and, in all cases, may not reproduce the full detail or exact shape of the parts shown. However, they represent parts which have the same or similar function.

SYMBOLS USED IN THIS CATALOG

@ - In «Quantity» column means «Use as Required».

Opt - In «Quantity» column means «Optional».

N - In «Numerical» column means «New Parts».

- A bold description indicates several parts.

Ski-Doo Model
Modèle Ski-Doo

Vehicle Codification
Code du véhicule

Rotax Engine Type
Type de moteur Rotax

Carburetor
Carburateur

TUNDRA II LT

3264

**Rotax «277»
(400 2057 00)**

**Mikuni VM 34-443
(403 1223 00)**

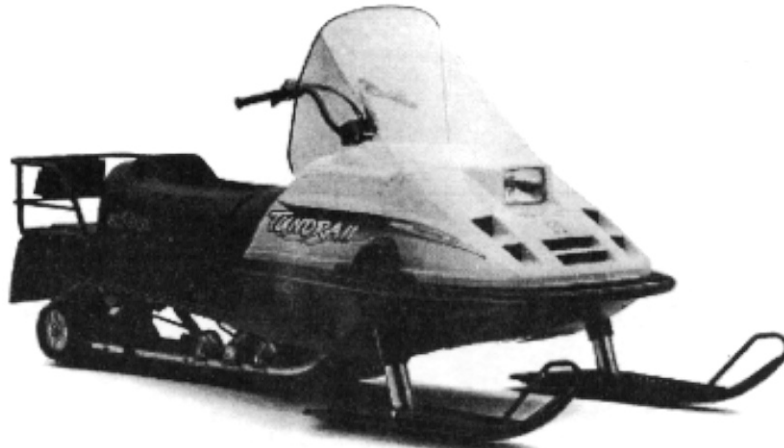

CATALOGUE DE PIÈCES

Les illustrations contenues dans ce catalogue indiquent la disposition des pièces les unes par rapport aux autres. Il est donc possible qu'elles ne rendent pas compte de la forme exacte de ces pièces ainsi que de leurs détails de fabrication. Ces illustrations ont pour but d'identifier des pièces qui remplissent la même fonction ou une fonction identique.

SYMBOLES UTILISÉS DANS CE CATALOGUE

@ - Dans la colonne «Quantité» signifie «Au besoin».

Opt - Dans la colonne «Quantité» signifie «En option».

N - Dans la colonne «Numérique» signifie «Nouvelle pièce».

- Une description en caractère gras signifie qu'il y a plus d'une pièce.

TABLE OF CONTENTS



Engine and Components A5 ⇨ A11

- Engine Support (A5, A6)
- Air Deflector (A5, A6)
- Exhaust Manifold, Muffler (A5, A6)
- Crankcase (A7, A8)
- Crankshaft, Pistons (A7, A8)
- Cylinder (A7, A8)
- Decompressor (A7, A8)
- Magneto (A9, A10)
- Fan Cowl, Cylinder Cowl (A9, A10)
- Rewind Starter (A11)



Oil Injection System A12, B1

- Oil Tank (A12, B1)
- Oil Lines (A12, B1)
- Oil Pump, Mounting Flange (A12, B1)



Fuel System B2 ⇨ B4

- Fuel Tank (B2, B3)
- Fuel Lines, Filters (B2, B3)
- Air Silencer (B2, B3)
- Throttle Handle and Cable (B2, B3)
- Primer (B2, B3)
- Carburetor (B4)
- Fuel Pump (B4)

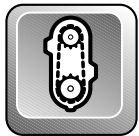

Transmission B5

- Chaincase (B5)



Pulleys B6, B7

- Drive Pulley, Belt (B6, B7)
- Driven Pulley (B6, B7)
- Brake Disk (B6, B7)
- Driven Pulley Support (B6, B7)



Brake and Belt Guard B8, B9

- Brake Handle and Cables (B8, B9)
- Brake Housing and Pads (B8, B9)
- Belt Guard (B8, B9)
- Brake Support (B8, B9)



Steering and Front Suspension B10, B11

- Steering System (B10)
- Front Suspension and Ski System (B11)



Track and Rear Suspension B12 ⇨ C3

- Drive Axle (B12)
- Track and Sprockets (B12)
- Rear Suspension System (C1⇨C3)



Frame and Body C4 ⇨ C9

- Seat and Rack (C4)
- Taillamp Housing (C4)
- Hitch (C4)
- Frame Ass'y, Front Bumpers (C5, C6)
- Bottom Pan (C5, C6)
- Snow Guard (C5, C6)
- Cab and Windshield (C7, C8)
- Headlamp Ass'y and Brackets (C7, C8)
- Cab Hinges and Latches (C7, C8)
- Decals (C9)



Electrical System C10

- Ignition Switch (C10)
- Kill, Dimmer Switch (C10)
- Voltage Regulator (C10)
- Brake Switch (C10)
- Electrical Terminals (C10)

TABLE DES MATIÈRES



Moteur et composants A5 ⇨ A11

- Support moteur (A5, A6)
- Déflecteur d'air (A5, A6)
- Collecteur d'échappement et silencieux (A5, A6)
- Carter (A7, A8)
- Vilbrequin, pistons (A7, A8)
- Cylindre (A7, A8)
- Décompresseur (A7, A8)
- Magnéto (A9, A10)
- Déflecteur de ventilateur et cylindre (A9, A10)
- Démarreur à rappel (A11)



Système d'injection d'huile A12, B1

- Réservoir d'huile (A12, B1)
- Conduits (A12, B1)
- Épaulement, pompe à l'huile (A12, B1)



Système d'alimentation B2 ⇨ B4

- Réservoir à essence (B2, B3)
- Conduits, Filtres (B2, B3)
- Silencieux d'admission (B2, B3)
- Logement de manette d'accélérateur et câble (B2, B3)
- Amorceur (B2, B3)
- Pompe à essence (B4)
- Carburateur (B4)

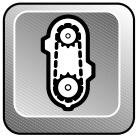

Transmission B5

- Carter de chaîne (B5)

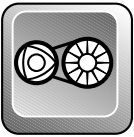

Poulies B6, B7

- Poulie motrice (B6, B7)
- Courroie d'entraînement (B6, B7)
- Poulie menée (B6, B7)
- Disque de frein (B6, B7)
- Support de poulie menée (B6, B7)

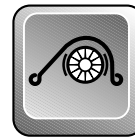

Frein et garde-courroie B8, B9

- Logement de manette de frein (B8, B9)
- Câble et gaine de frein (B8, B9)
- Étrier et plaquettes de frein (B8, B9)
- Garde-courroie (B8, B9)
- Support de frein (B8, B9)



Direction et Suspension avant B10, B11

- Système de direction (B10)
- Suspension avant et ski (B11)



Chenille et suspension arrière B12 ⇨ C3

- Essieu moteur (B12)
- Chenille et barbotins (B12)
- Suspension arrière (C1⇨C3)



Châssis et carrosserie C4 ⇨ C9

- Siège et porte-bagages (C4)
- Feu arrière (C4)
- Attelage (C4)
- Cadre ass. et pare-chocs avant (C5, C6)
- Coque (C5, C6)
- Garde-neige (C5, C6)
- Capot et pare-brise (C7, C8)
- Phare avant et supports (C7, C8)
- Chamnières et attaches de capot (C7, C8)
- Decalcomanie (C9)



Système électrique C10

- Interrupteur d'allumage, d'urgence (C10)
- Régulateur de tension (C10)
- Interrupteur de frein (C10)
- Commutateur d'éclairage (C10)
- Raccord électriques (C10)

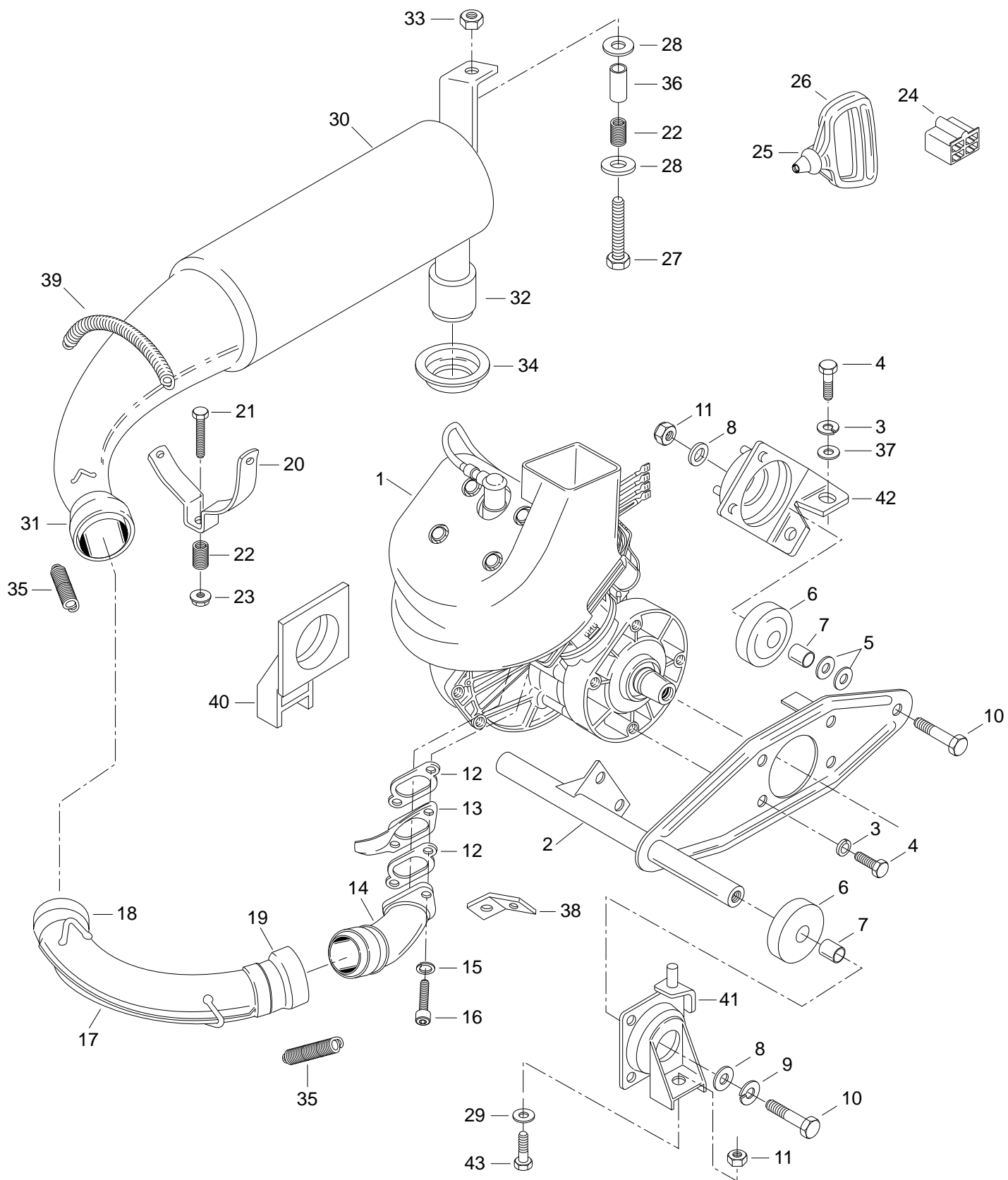



Engine Support and Muffler Support moteur et silencieux

TUNDRA II LT

1	400 2057 00	ROTAX Engine 277	Moteur ROTAX 277	1
2	512 0480 00	Engine Support	Support moteur	1
3	224 7811 40	Lock Washer 8 mm	Rondelle-frein 8 mm	9
4	222 0820 65	Hex Screw M8 x 20	Vis hex. M8 x 20	9
5	504 0398 00	Shim	Cale	@
6→7	570 1268 00	Mounting Rubber	Tampon d'ancrage	3
7	517 1671 00	Bushing	Douille	3
8	506 0631 00	Washer	Rondelle	3
9	224 7011 70	Lock Washer 10 mm	Rondelle-frein 10 mm	2
10	222 0040 65	Hex Screw M10 x 40	Vis hex. M10 x 40	3
11	228 5010 45	Elastic Nut M10	Écrou élastique M10	3
12	420 8318 46	Gasket	Joint d'étanchéité	2
13	420 9757 20	Air Deflector	Défecteur d'air	1
14	420 9788 36	Exhaust Manifold	Collecteur d'échappement	1
15	420 9457 52	Lock Washer 8 mm	Rondelle-frein 8 mm	2
16	222 9830 65	Allen Screw M8 x 30	Vis Allen M8 x 30	2
17→19	514 0426 00	Exhaust Elbow	Coude d'échappement	1
18	420 8786 61	Male Ball Joint	Joint à rotule mâle	1
19	514 0211 00	Female Ball Joint	Joint à rotule femelle	1
20	514 0179 00	Muffler Support	Support de silencieux	1
21	222 0645 65	Hex Screw M6 x 45	Vis hex. M6 x 45	1
22	414 9137 00	Spring	Ressort	2
23	228 5610 45	Elastic Nut M6	Écrou élastique M6	1
24	409 2049 00	Female Connector Housing	Logement raccord femelle	@
25	420 9604 15	Rubber Buffer	Butoir en caoutchouc	1
26	420 8521 76	Starter Handle	Poignée du démarreur	1
27	222 0850 65	Hex Screw M8 x 50	Vis hex. M8 x 50	1
28	224 0802 51	Washer 8,4 mm	Rondelle 8,4 mm	1
29	224 0022 51	Washer 10,5 mm	Rondelle 10,5 mm	2
30→32	514 0320 00	Muffler	Silencieux	1
31	420 9735 30	Female Ball Joint	Joint à rotule femelle	1
32	514 0265 01	Ring	Bague	1
33	228 5810 45	Nut M8	Écrou M8	1
34	570 1413 00	Exhaust Grommet	Bague d'échappement	1
35	517 1821 00	Spring	Ressort	3
36	514 0358 00	Guide	Guide	1
37	224 0812 01	Washer 8,4 mm	Rondelle 8,4 mm	3
38	420 9531 70	Bracket	Attache	1
39	517 2683 00	Spring	Ressort	1



Engine Support and Muffler Support moteur et silencieux

TUNDRA II LT

40	512 0483 00	R.H. Front Support.....	Support avant droit	1
41	512 0484 00	L.H. Front Support	Support avant gauche	1
42	512 0504 00	Rear Support	Support arrière	1
43	222 0025 65	Hex Screw M10 x 25.....	Vis hex. M10 x 25	2

- 32 — 
- 31 — 
- 32 — 
- 31 — 

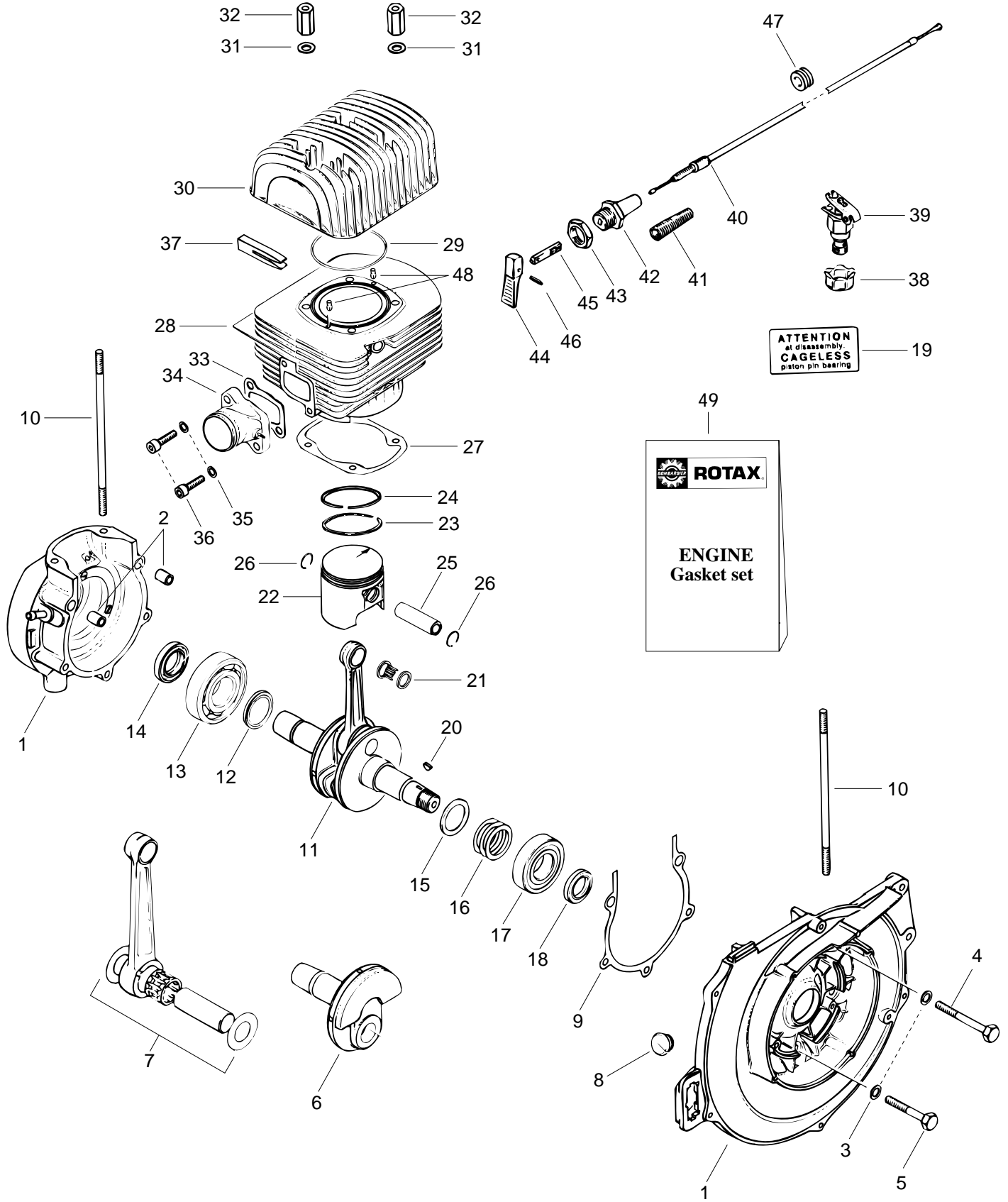



Crankcase and Cylinder

Carter et cylindre

TUNDRA II LT

1 → 5	420 8867 06	Crankcase	Carter	1
2	420 2291 50	Stud	Goujon	2
3	420 9457 52	Lock Washer 8 mm	Rondelle-frein 8 mm	7
4	222 0875 65	Hex Screw M8 x 75	Vis hex. M8 x 75	2
5	222 0855 65	Hex Screw M8 x 55	Vis hex. M8 x 55	3
6	420 9199 51	Half Crankshaft PTO Side	Demi vilebrequin côté PDM	1
7	420 9953 09	Rod Repair Kit	Ens. de tige de réparation	1
8	420 9602 87	Cable Grommet	Passe-câble	1
9	420 8500 60	Crankcase Gasket	Joint d'étanchéité du carter	1
10	420 8406 20	Stud M8 x 175	Goujon M8 x 175	4
11	420 9953 01	Crankshaft	Vilebrequin	1
12	420 8274 40	Distance Ring, PTO Side	Rondelle d'écartement, côté PDM	1
13	420 9325 71	Ball Bearing, PTO Side	Roulement à bille, côté PDM	1
14	420 8500 50	Seal, PTO Side	Anneau d'étanchéité, côté PDM	1
15	420 8274 40	Distance Ring, MAG Side	Rondelle d'écartement, côté MAG	1
16	420 9445 82	Shim 0,3 mm	Cale 0,3 mm	@
	420 9445 83	Shim 0,1 mm	Cale 0,1 mm	@
	420 9445 84	Shim 0,5 mm	Cale 0,5 mm	@
	420 9445 86	Shim 0,2 mm	Cale 0,2 mm	@
17	420 9325 81	Ball Bearing, MAG Side	Roulement à bille, côté MAG	1
18	420 2304 25	Seal, MAG Side	Anneau d'étanchéité, côté MAG	1
19	420 8972 80	Warning Decal	Décalque d'avertissement	1
20	420 2460 55	Woodruff Key 3 x 3,7	Clavette de Woodruff 3 x 3,7	1
21	420 8323 20	Needle Cage	Roulement à aiguilles	1
22 → 24	420 9962 45	Piston with 2 Rings, 72,0 mm	Piston avec 2 segments, 72,0 mm .	1
	420 9962 46	Piston with 2 Rings, 72,25 mm	Piston avec 2 segments, 72,25 mm .	Opt
	420 9962 47	Piston with 2 Rings, 72,5 mm	Piston avec 2 segments, 72,5 mm .	Opt
23	420 9158 50	Rectangular Ring 72,0 mm	Segment rectangulaire, 72,0 mm	1
	420 9158 51	Rectangular Ring 72,25 mm	Segment rectangulaire, 72,25 mm	Opt
	420 9158 52	Rectangular Ring 72,5 mm	Segment rectangulaire, 72,5 mm	Opt
24	420 2152 35	Semi-Trapezoidal Ring 72,0 mm	Segm. semi-trapézoidale, 72,0 mm	1
	420 2152 36	Semi-Trapezoidal Ring 72,25 mm	Segm. semi-trapézoidale, 72,25 mm	Opt
	420 2152 37	Semi-Trapezoidal Ring 72,5 mm	Segm. semi-trapézoidale, 72,5 mm	Opt
25	420 9161 85	Gudgeon Pin	Axe de piston	1
26	420 9457 35	Circlip	Circlip	2
27	420 8318 58	Cylinder Flange Gasket	Joint d'étanchéité de cylindre	1
28	420 9132 17	Cylinder with Sleeve	Cylindre avec chemise	1
29	420 8505 40	O-Ring	Joint torique	1
30	420 8237 87	Cylinder Head	Culasse	1



Crankcase and Cylinder Carter et cylindre

TUNDRA II LT

31	420 2503 11	Washer 8,4 mm	Rondelle 8,4 mm	4
32	420 8420 10	Hex Distance Nut M8 x 27,5	Écrou d'écartement hex. M8 x 27,5	4
33	420 8318 61	Intake Manifold Gasket	Joint d'étanchéité	1
34	420 8674 08	Intake Manifold	Tubulure d'admission	1
35	420 9457 52	Lock Washer 8 mm	Rondelle-frein 8 mm	2
36	222 9830 65	Allen Screw M8 x 30	Vis Allen M8 x 30	2
37	420 8601 00	Rubber Fin	Ailette de caoutchouc	1
38	420 8302 40	Locking and Sealing Sleeve	Manchon de blocage et d'étanchéité .	1
39	420 9845 11	Decompressor	Décompresseur	1
40	420 9999 69	Decompressor Cable	Câble de décompresseur	1
41	420 2392 30	Spring	Ressort	1
42	420 9310 80	Switch Housing	Boitier d'interrupteur	1
43	420 8424 80	Cap Nut M18	Écrou capuchon M18	1
44	420 9311 00	Switch Lever	Levier interrupteur	1
45	420 9310 90	Rod	Tige	1
46	420 9297 80	Dowel Tube 2 x 12	Tube 2 x 12	1
47	420 9604 45	Grommet	Passe-fils	1
48	420 9296 50	Drive Pin	Goupille d'assemblage	2
49	420 9920 68	Engine Gasket Set	Ens. joint d'étanchéité	1

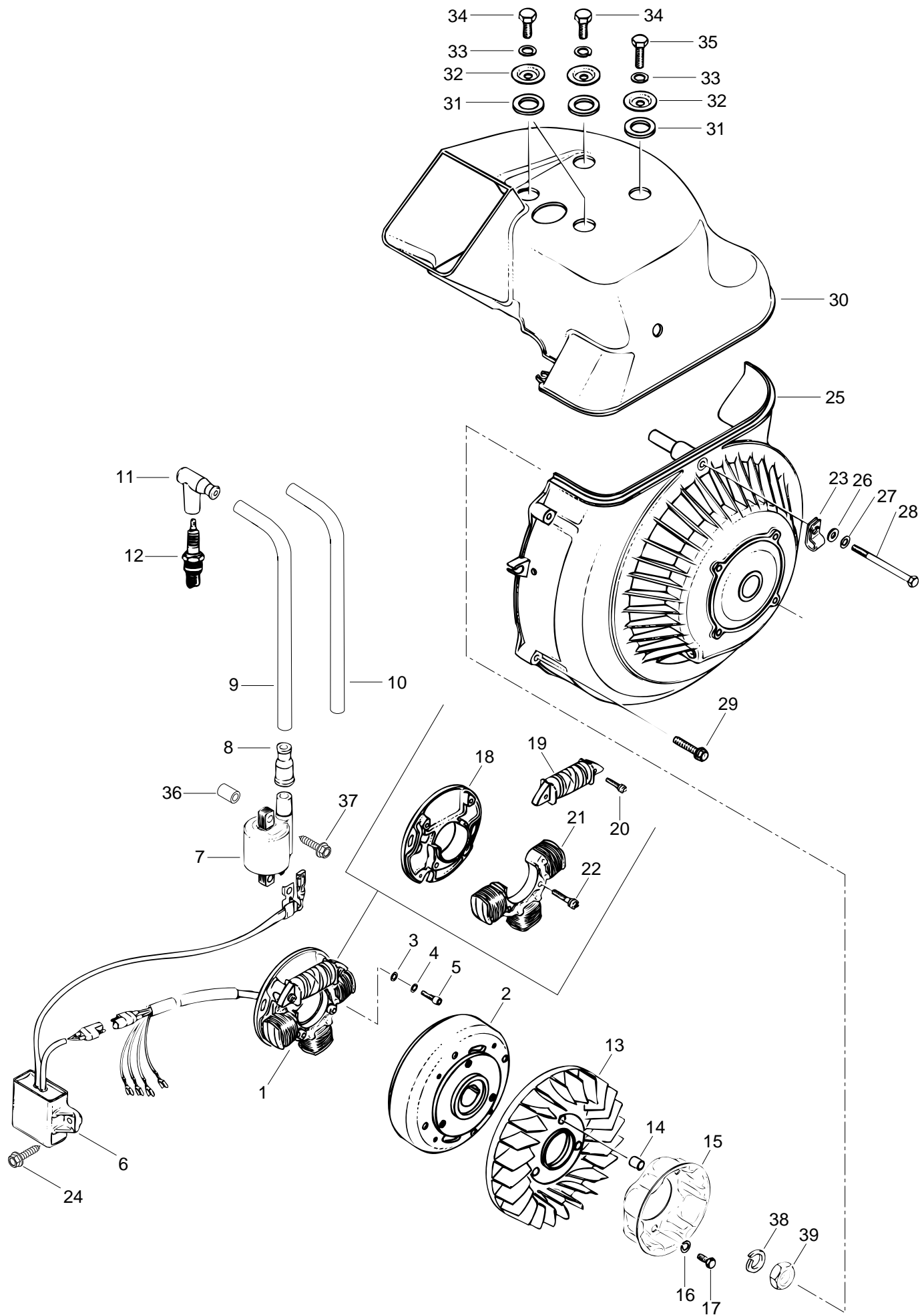



Magneto Magnéto

TUNDRA II LT

1-2	420 8866 90	Magneto 12V 160W Ass'y	Magnéto 12V 160W ass.	1
2	410 9148 00	Magneto Flywheel	Volant moteur	1
3	420 8278 00	Washer 5,5 mm	Rondelle 5,5 mm	2
4	420 9457 50	Lock Washer 5 mm	Rondelle-frein 5 mm	2
5	420 8405 15	Allen Screw M5 x 18	Vis Allen M5 x 18	2
6	410 9158 00	C.D. Box	Boîte électronique	1
7-9	410 9159 00	Ignition Coil	Bobine d'allumage	1
8	420 9605 50	Protection Cap	Capuchon de protection	1
9	420 9651 53	Ignition Cable	Câble d'allumage	1
10	420 2604 38	Hose Protector	Protecteur de boyau	1
11	414 8640 00	Spark Plug Protector	Capuchon antiparasite	1
12	414 9611 00	Spark Plug NGK9ES	Bougie NGK BR9ES	1
13	420 8664 35	Fan	Ventilateur	1
14	420 8474 40	Distance Sleeve	Douille d'écartement	3
15	420 8524 15	Starting Pulley	Poulie de démarrage	1
16	420 9457 52	Lock Washer 8 mm	Rondelle-frein 8 mm	3
17	222 0825 65	Hex M8 x 25	Vis hex. M8 x 25	3
18	410 9151 00	Armature Plate	Plateau d'armature	1
19	410 9152 00	Generation Coil	Bobine génératrice d'allumage	1
20	420 9408 10	Allen Screw M5 x 22	Vis Allen M5 x 22	2
21	410 9162 00	Lighting Coil	Bobine d'éclairage	1
22	410 9139 00	Screw with Washer	Vis avec rondelle	2
23	420 8512 40	Clamp	Bride	1
24	365 9014 00	Hex Self Tapping Screw	Vis hex autotaraudeuse	2
25	420 8102 87	Fan Cowl	Déфлекteur de ventilateur	1
26	224 0611 21	Washer 6,4 mm	Rondelle 6,4 mm	1
27	420 9457 51	Lock Washer 6 mm	Rondelle-frein 6 mm	1
28	222 0675 65	Hex Screw M6 x 75	Vis hex M6 x 75	1
29	420 9415 05	Self Tapping Screw M6 x 30	Vis autotaraudeuse hex M6 x 30	5
30	420 9100 21	Cylinder Cowl	Déфлекteur de cylindre	1
31	420 9608 60	Rubber Washer	Rondelle de caoutchouc	4
32	420 8271 40	Cowl Cover	Capuchon de déфлекteur	4
33	420 9457 52	Lock Washer 8 mm	Rondelle-frein 8 mm	4
34	222 0816 65	Hex Screw M8 x 16	Vis hex M8 x 16	3
35	222 0825 65	Hex Screw M8 x 25	Vis hex. M8 x 25	1
36	517 2032 00	Spacer	Entretoise	2



Magneto Magnéto

TUNDRA II LT

37	— XXX —	Hex Self Tapping Screw	Vis hex. autotaraudeuse	2
38	420 9457 59	Lock Washer 22 mm	Rondelle-frein 22 mm.....	1
39	420 8422 30	Nut M22	Écrou M22	1

Parts marked with «XXX» are not available as spare parts.

Les articles marqués d'un «XXX» ne sont pas disponibles comme pièces de remplacement.

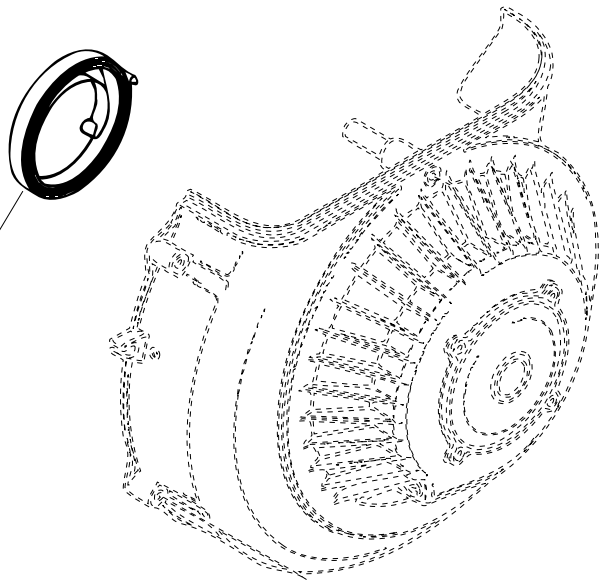
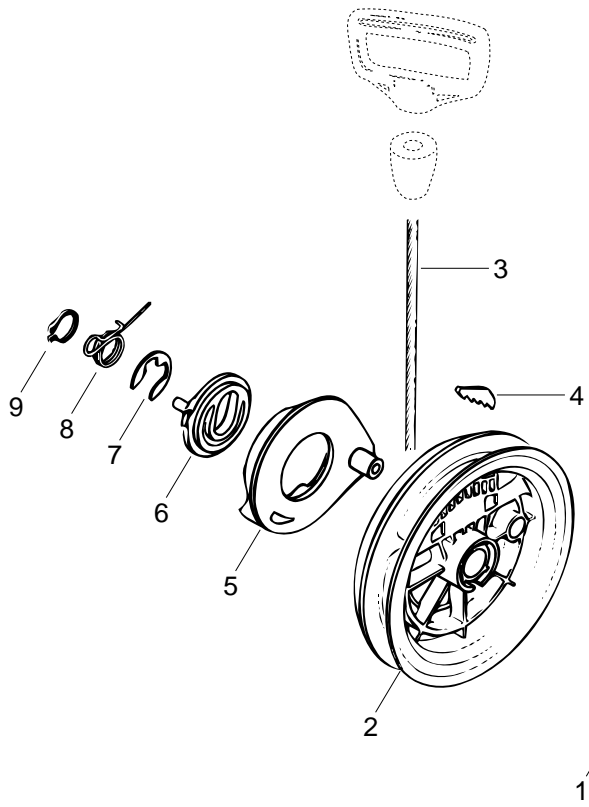



Rewind Starter Démarreur à rappel

TUNDRA II LT

1	420 9391 15	Cartridge	Ressort à rappel	1
2	420 8522 83	Rope Sheave	Poulie du démarreur	1
3	412 5001 00	Starter Rope 2200 mm	Corde du démarreur 2200 mm	@
4	420 8520 70	Key Clamp	Coin	1
5	420 8522 90	Pawl	Cliquet	1
6	420 8523 01	Pawl Lock	Arrêt de cliquet	1
7	420 8453 00	Circlip	Circlip	1
8	420 9389 85	Locking Spring	Ressort d'arrêt	1
9	420 9457 70	Locking Ring	Circlip	1

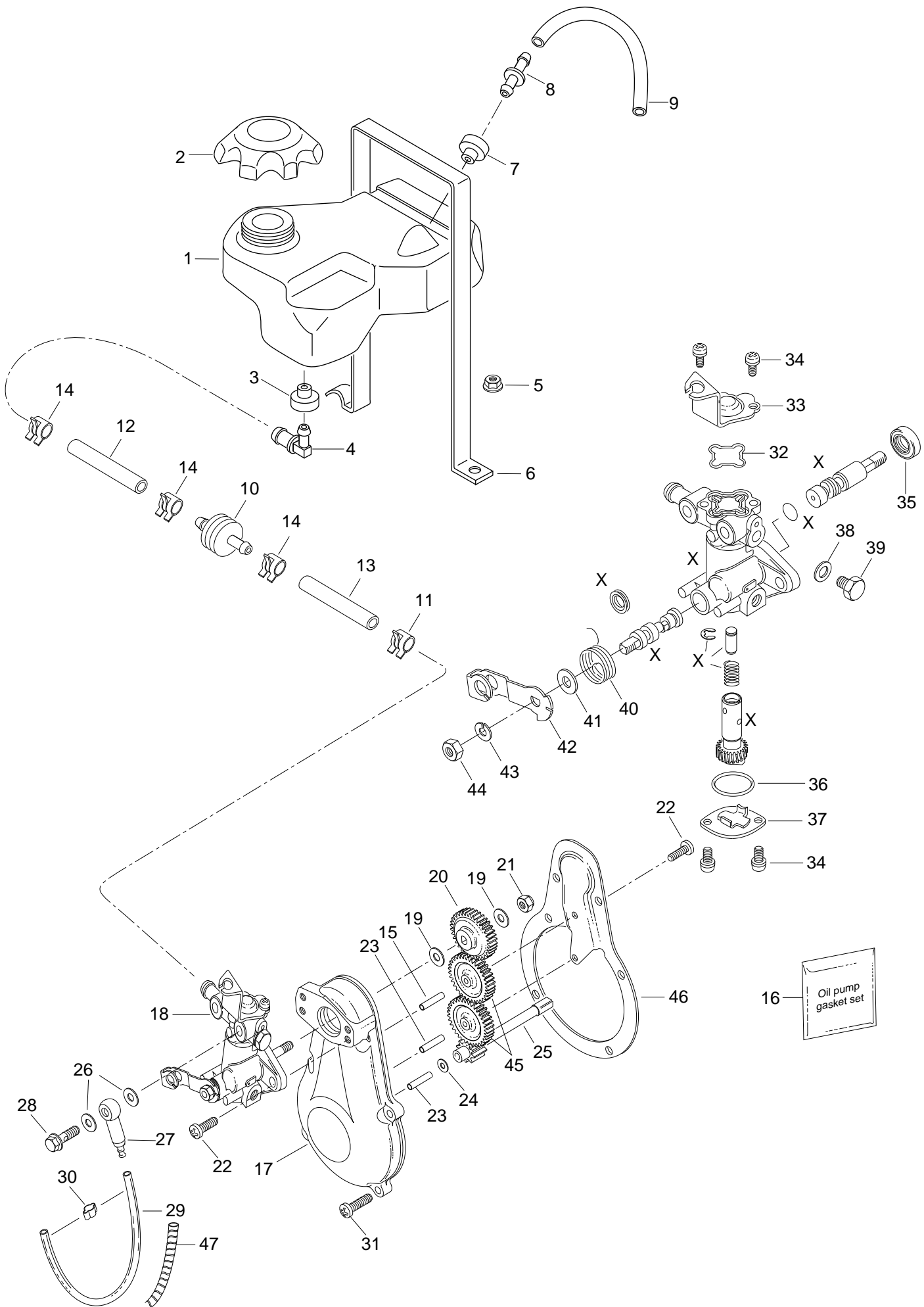



Oil Injection System

Système à injection d'huile

TUNDRA II LT

1	571 0086 00	Injection Oil Tank	Réservoir d'huile à injection	1
2	572 0396 00	Oil Tank Cap	Bouchon du réservoir d'huile	1
3	570 1351 00	Grommet	Bague isolante	1
4	414 6502 00	Male Connector 90°	Raccord mâle 90°	1
5	228 7610 45	Elastic Flanged Nut M6	Écrou élastique à épaulement M6	1
6	517 2634 00	Strip Retainer	Languette de retenue	1
7	570 0277 00	Grommet	Passe-fils	1
8	414 8247 00	Check Valve	Soupape de retenue	1
9	414 0511 00	Hose	Boyau	@
10	414 5365 00	Oil Filter	Filtre à l'huile	1
11	414 4207 00	Spring Clip	Pince à ressort	1
12	414 5333 00	Oil Line	Conduit d'huile	@
13	414 5333 00	Oil Line	Conduit d'huile	@
14	414 4152 00	Spring Clip	Pince à ressort	3
15	420 2329 70	Needle Pin	Goupille de roulement	1
16	420 9950 40	Gasket Set.....	Ens. de joints d'étanchéité.....	1
17	420 8101 10	Oil Mounting Flange	Épaulement de pompe à huile	1
18	404 0459 00	Oil Pump	Pompe à huile	1
19	420 9279 45	Washer 6,2 mm	Rondelle 6,2 mm	2
20	420 9359 30	Oil Pump Gear 27 Teeth	Roue d'engrenage à 27 dents	1
21	228 5610 45	Elastic Nut M6	Écrou élastique M6	1
22	420 8419 70	Screw M5,5 x 16	Vis M5,5 x 16	4
23	420 2324 20	Needle Pin	Goupille de roulement	2
24	420 2440 73	Washer 4,3 mm	Rondelle 4,3 mm	1
25	420 9359 75	9 Teeth Gear	Pignon à 9 dents	1
26	404 1466 00	Oil Banjo Gasket	Joint d'étanchéité de raccord banjo ...	2
27	420 9560 10	Banjo	Raccord banjo	1
28	404 1468 00	Banjo Screw	Vis du raccord banjo	1
29	414 4138 00	Oil Line	Conduit d'huile	@
30	420 8538 40	Clamp	Bride	2
31	420 8419 75	Self Tapping Screw M5 x 20	Vis autotaraudeuse M5 x 20	4
32	420 2304 77	O-Ring	Joint torique	1
33	420 9560 32	Plate	Plateau	1
34	420 8416 20	Screw with Lock Washer	Vis et rondelle-frein	4
35	420 8502 30	Seal	Anneau d'étanchéité	1
36	420 2303 70	O-Ring	Joint torique	1
37	420 2560 77	Cam Casing Plate	Plateau de boîtier de la came	1
38	420 2275 05	Washer	Rondelle	1
39	420 8415 80	Hex Screw M6 x 8	Vis hex. M6 x 8	1



Oil Injection System Système à injection d'huile

TUNDRA II LT

40	420 2396 70	Spring	Ressort	1
41	— XXX —	Washer	Rondelle	1
42	404 1465 00	Lever	Levier	1
43	420 9457 51	Lock Washer M6	Rondelle-frein M6	1
44	420 2426 21	Nut M6	Écrou M6	1
45	420 8342 10	Oil Pump Gear	Engrenage de pompe à huile	2
46	420 8101 22	Pump Flange	Épaulement de pompe	1
47	420 9607 25	Insulator	Gaine isolante	@

Parts marked with «XXX» are not available as spare parts.

Les articles marqués d'un «XXX» ne sont pas disponibles comme pièces de remplacement.

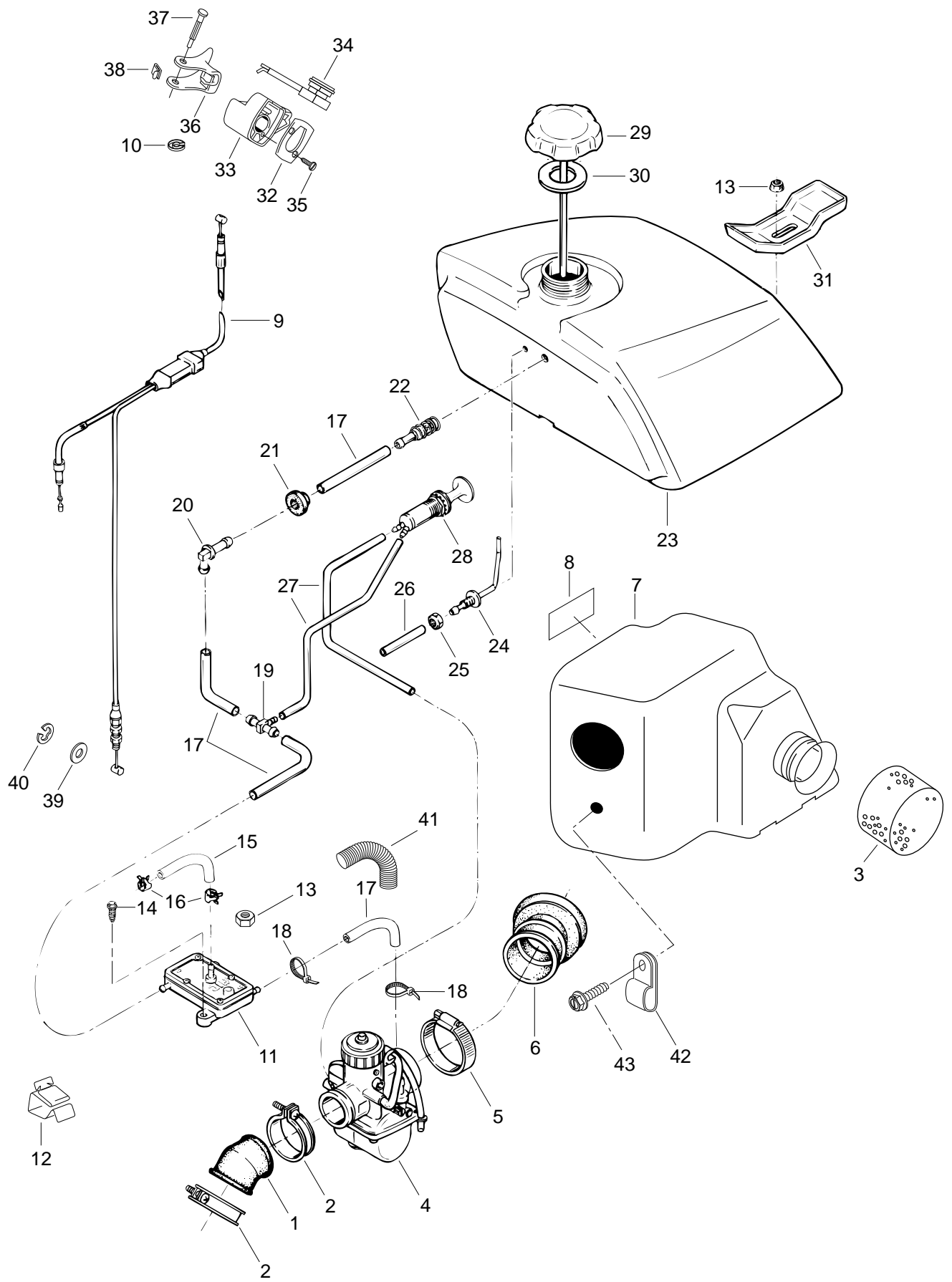



Fuel System

Système d'alimentation

TUNDRA II LT

1	570 0254 00	Rubber Flange	Épaulement de caoutchouc	1
2	408 8019 00	Gear Clamp	Collier de serrage	2
3	414 8199 00	Filter	Filtre	1
4	403 1223 00	Carburetor VM 34-443	Carburateur VM 34-443	1
5	408 8020 00	Gear Clamp	Collier de serrage	1
6	570 1363 00	Intake Adaptor	Adapteur d'admission	1
7	572 0555 00	Air Silencer	Silencieux d'admission	1
8	414 1615 00	Warning Decal	Décalque d'avertissement	1
9	414 9356 00	Throttle Cable & Housing	Câble et gaine d'accélérateur	1
10	371 9040 00	Circlip	Circlip	1
11	403 8008 00	Fuel Pump	Pompe d'alimentation	1
12	414 2273 00	Retaining Clip	Pince de retenue	@
13	228 7610 45	Elastic Flanged Nut M6	Écrou élastique à épaulement M6	5
14	365 9011 00	Self Tapping Screw 1/2 x 3/4	Vis autotaraudeuse 1/2 x 3/4	1
15	414 2867 00	Impulse Hose 9" (228 mm)	Conduite de pulsation 9" (228 mm)	@
16	414 4207 00	Spring Clamp	Bride à ressort	2
17	414 0511 00	Fuel Line	Conduit d'essence	@
18	414 1152 00	Tie Rap	Attache	2
19	414 2225 00	Tee	Raccord en «T»	1
20	414 5806 00	Male Connector	Raccord mâle	1
21	570 1351 00	Grommet	Bague isolante	1
22	414 8657 00	Fuel Filter	Filtre à essence	1
23	571 0090 00	Fuel Tank	Réservoir à essence	1
24	513 0311 00	Air Vent Fitting	Raccord de conduit d'aération	1
25	396 3022 00	Nut 5/16-18	Écrou 5/16-18	1
26	414 2969 00	Air Vent Tube (Feet)	Conduit d'aération (pied)	1
27	414 2969 00	Primer Tube	Conduit d'essence	@
28	414 4792 00	Primer Valve	Amorceur	1
29→30	572 1383 00	Fuel Tank Cap	Bouchon de réservoir à essence ..	1
30	570 1348 00	Gasket	Joint d'étanchéité	1
31	517 1595 00	Seat Bracket	Attache de siège	2
32	572 0662 00	Cover	Couvercle	1
33	572 0654 00	Throttle Handle Housing	Logement de manette d'accélérateur ..	1
34	410 2094 00	Kill Switch	Interrupteur d'urgence	1
35	732 6030 01	Self Tapping Screw M3 x 16	Vis autotaraudeuse M3 x 16	2
36	572 0635 00	Throttle Handle	Manette d'accélérateur	1
37	414 2427 00	Pin	Goupille	1
38	510 0031 00	Stopper	Butée	1



Fuel System Système d'alimentation

TUNDRA II LT

39	414 7533 00	Washer	Rondelle	1
40	414 7535 00	Circlip	Circlip	1
41	414 6124 00	Housing	Gaine	@
42	414 3516 00	Clip	Pince	1
43	365 9014 00	Hex Self Tapping Screw	Vis hex autotaraudeuse	1

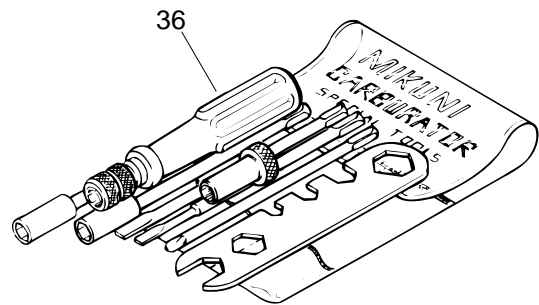
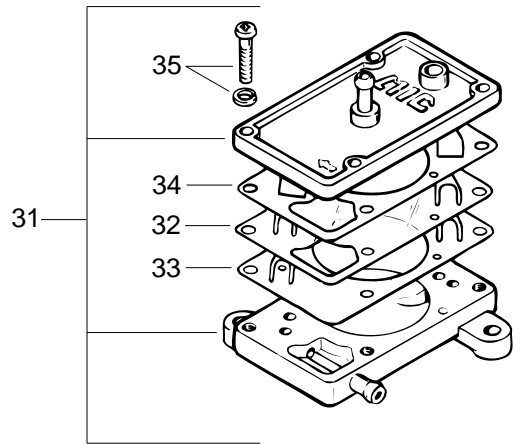
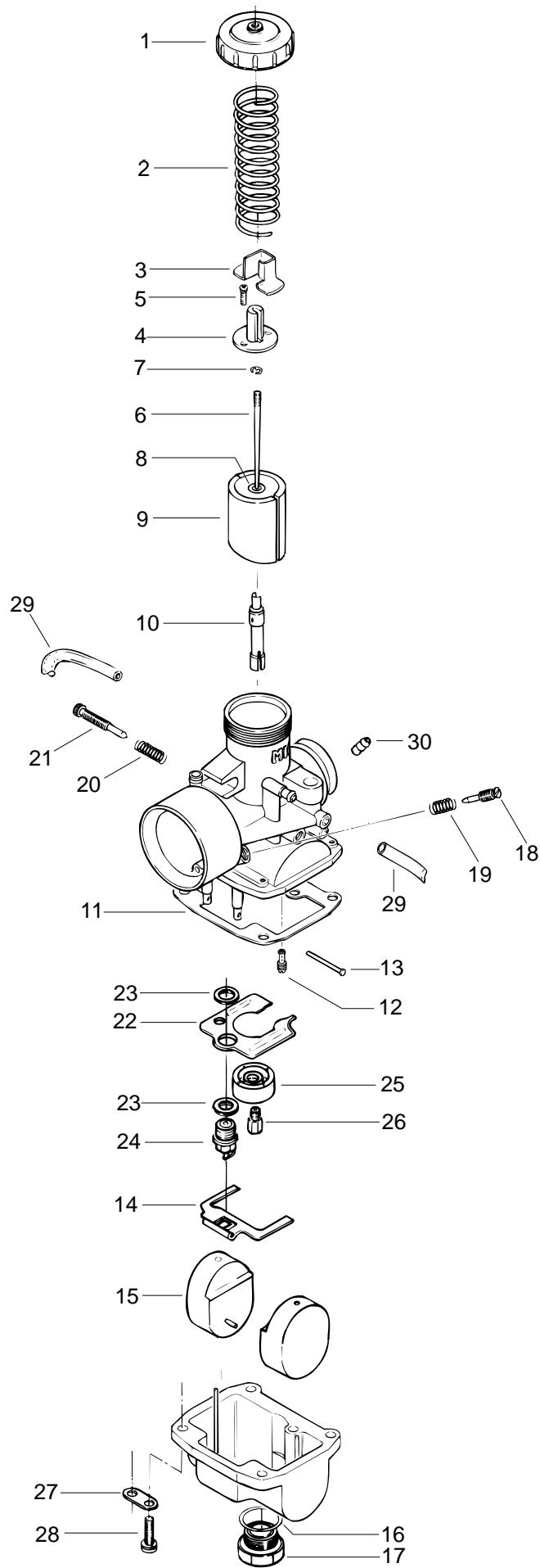

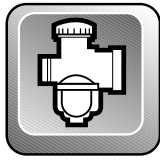

Carburetor Carburateur

TUNDRA II LT

1 → 30	403 1223 00	Carburetor VM 34-443	Carburateur VM 34-443	1
1	404 1058 00	Mixing Chamber Cover	Couvercle	1
2	404 1527 00	Throttle Valve Spring	Ressort du tiroir d'accélérateur	1
3	404 1221 00	Cover	Couvercle de raccord	1
4	404 1229 00	Connector	Raccord	1
5	404 1213 00	Screw with Lock Washer	Vis avec rondelle-frein	2
6	404 1019 00	Jet Needle JN 6DH4-2	Aiguille JN 6DH4-2	1
7	404 1524 00	Circlip	Circlip	1
8	404 1170 00	Packing	Joint tampon	1
9	404 1284 00	Throttle Valve 2.5	Tiroir d'accélérateur 2.5	1
10	404 1169 00	Needle Jet NJ 159-0-8	Gicleur d'aiguille NJ 159-0-8	1
11	404 1042 00	Gasket	Joint d'étanchéité de la cuve	1
12	404 1091 00	Pilot Jet PJ 40	Gicleur du ralenti PJ 40	1
13	404 1033 00	Float Arm Pin	Goupille de levier de flotteur	1
14	404 1076 00	Float Arm	Levier de flotteur	1
15	404 1071 00	Float	Flotteur	2
16	404 1073 00	O-ring	Joint torique	1
17	404 1074 00	Plug Screw	Bouchon d'accès	1
18	404 1023 00	Idle Adjusting Screw	Vis du mélange du ralenti	1
19	404 1018 00	Idle Adjusting Screw Spring	Ressort de la vis du ralenti	1
20	404 1017 00	Throttle Stop Screw Spring	Ressort de la vis du ralenti	1
21	404 1487 00	Throttle Stop Screw	Vis du ralenti	1
22	404 1096 00	Baffle Plate	Chicane	1
23	404 1016 00	Gasket	Joint d'étanchéité	2
24	404 1032 00	Needle Valve	Soupape d'admission	1
25	404 1109 00	Baffle Ring	Bague de la chicane	1
26	404 1190 00	Main Jet MJ 190	Gicleur principal MJ 190	1
27	404 1030 00	Tube Retainer Plate	Guide du tuyau d'aération	2
28	404 1020 00	Screw & Lock Washer	Vis et rondelle-frein	4
29	404 1098 00	Vent Tube	Tuyau d'aération	2
30	404 1276 00	Nipple	Adapteur d'amorceur	1
31 → 35	403 8008 00	Fuel Pump Complete	Pompe d'alimentation	1
32	404 9017 00	Diaphragm	Diaphragme	1
33	404 9018 00	Membrane	Membrane	1
34	404 9016 00	Packing (Cap)	Joint d'étanchéité du couvercle	1
35	404 1185 00	Screw	Vis	4
36	404 1120 00	Tool Kit	Ens. d'outils	1
37	861 7434 00	High Altitude Kit (Not Shown)	Ens. haute altitude (non ill.)	Opt

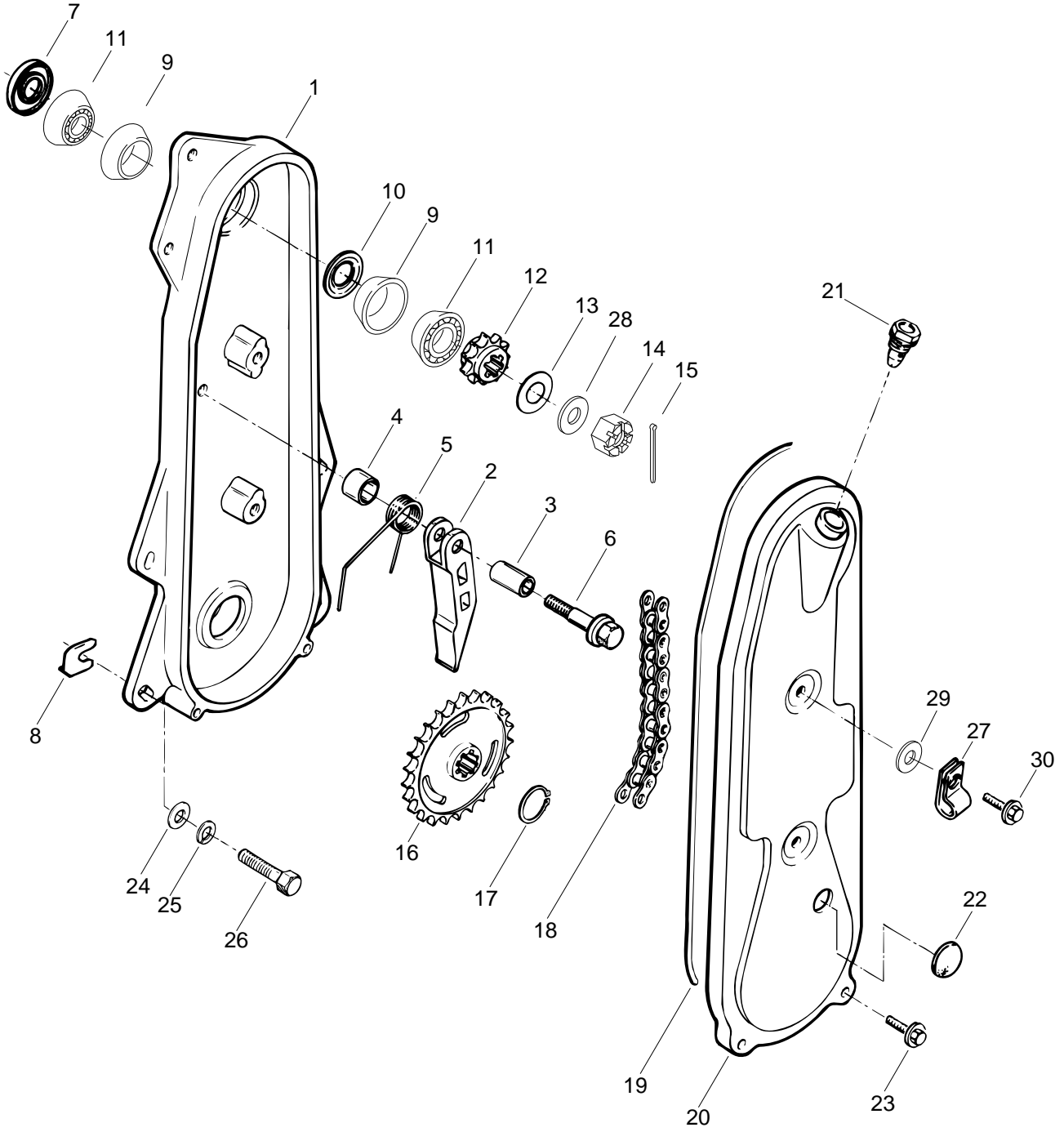

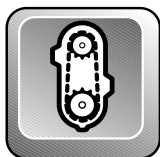

Chaincase Carter de chaîne

TUNDRA II LT

1	504 0880 00	Chain Case	Carter de chaîne	1
2	572 0416 00	Chain Tensioner	Tendeur de chaîne	1
3	504 0516 00	Spacer Bushing	Douille entretoise	1
4	504 0182 00	Spacer	Entretoise	1
5	414 1306 00	Spring	Ressort	1
6	732 6010 50	Flanged Self Locking Screw M6 x 40	Vis autofreinée à épaulement M6 x 40	1
7	406 3006 00	Oil Seal	Anneau d'étanchéité d'huile	1
8	504 0398 00	Shim	Cale	@
9	405 0003 00	Bearing Cup	Cône de roulement	2
10	504 0058 00	Oil Retainer Ring	Déflexeur d'huile	1
11	405 0004 00	Conical Ball Bearing	Roulement à billes conique	2
12	504 0885 00	14 Teeth Single Sprocket	Pignon de chaîne simple à 14 dents ...	1
13	414 8237 00	Washer	Rondelle	1
14	732 6100 56	Castle Nut M12	Écrou crénelé M12	1
15	371 8008 00	Cotter Pin	Goupille fendue	1
16	504 0886 00	25 Teeth Single Sprocket	Pignon de chaîne simple à 25 dents ...	1
17	371 9049 00	Circlip	Circlip	1
18	412 1063 00	Driving Chain, Single Pitch, 62 Links ..	Chaîne à pas simple 62 maillons	1
19	570 0459 00	Gasket	Joint d'étanchéité	1
20	504 0881 00	Chaincase Cover	Couvercle de carter de chaîne	1
21	572 0406 00	Breather	Reniflard	1
22	570 0406 00	Chaincase Plug	Bouchon de carter de chaîne	1
23	732 6000 02	Self Tapping Screw M6 x 16	Vis autotaraudeuse M6 x 16	2
24	224 0811 71	Washer	Rondelle	4
25	224 7811 40	Lock Washer 8 mm	Rondelle-frein 8 mm	4
26	222 0825 65	Hex Screw M8 x 25	Vis hex. M8 x 25	4
27	414 1760 00	Clip	Pince	1
28	504 0495 00	Special Washer	Rondelle spéciale	1
29	224 0612 01	Washer	Rondelle	2
30	732 6000 05	Self Tapping Screw M6 x 20	Vis autotaraudeuse M6 x 20	2

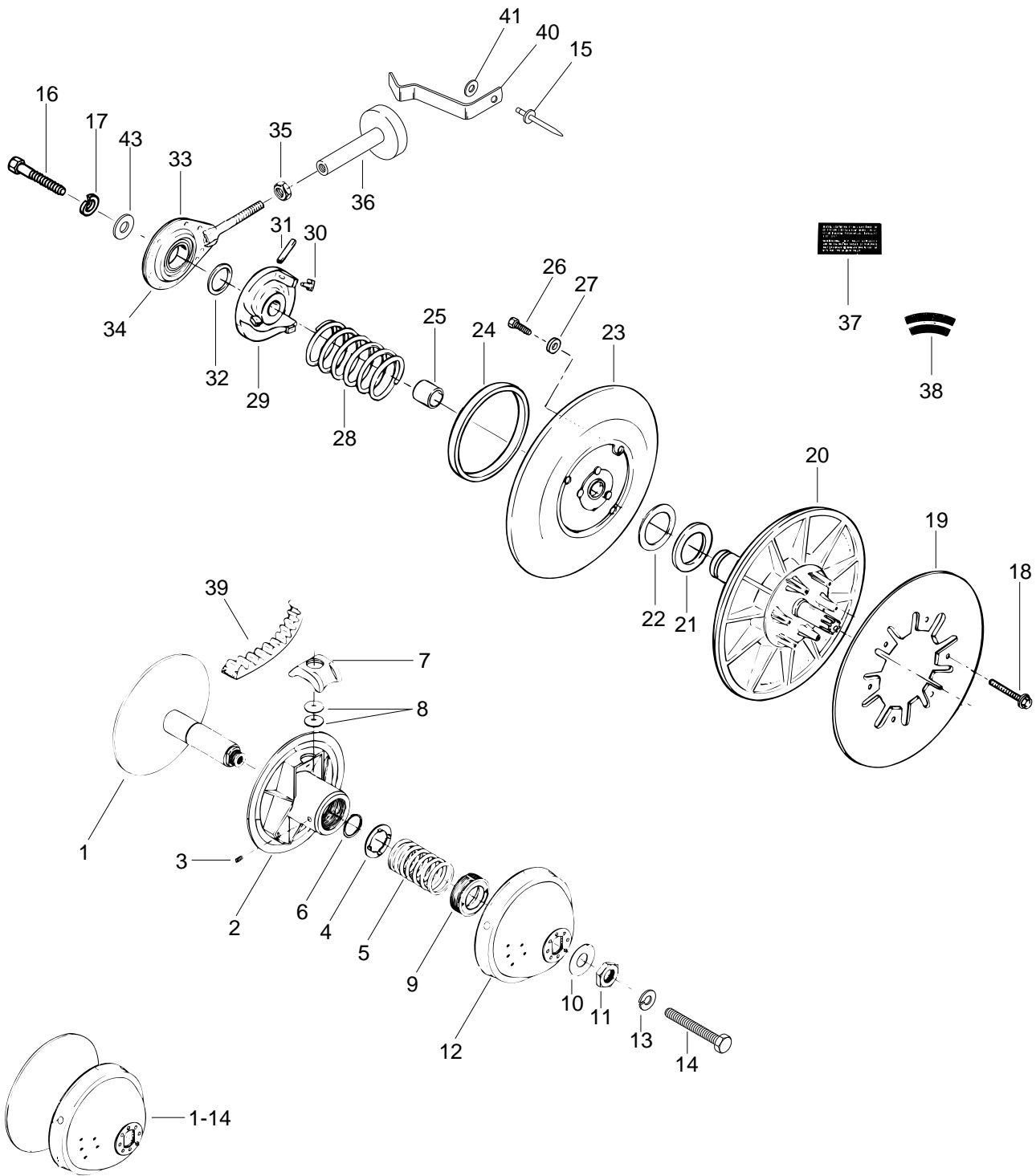

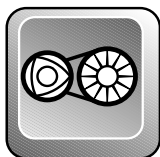

Pulleys Poulies

TUNDRA II LT

N 1→14	417 1206 00	Drive Pulley Ass'y	Poulie motrice ass.	1
1	417 1160 00	Inner Half	Demi-poulie fixe	1
N 2	417 1205 00	Outer Half	Demi-poulie coulissante	1
3	417 1168 00	Locking Screw	Vis de blocage	1
4	417 1162 00	Washer-Guide	Rondelle guide	1
5	417 1159 00	Spring	Ressort	1
6	417 1161 00	Circlip	Circlip	1
7	417 1143 00	Centrifugal Block	Bloc centrifuge	3
8	417 1145 00	Capsule	Capsule	6
9	417 1173 00	Support-Bushing	Support de coussinet	1
10	417 1165 00	Washer-Retainer	Rondelle de retenue	1
11	417 1183 00	Nut	Écrou	1
12	417 1186 00	Cap	Capuchon	1
13	392 0028 00	Lock Washer	Rondelle frein	1
14	417 1138 00	Hex Screw 1/2-20 x 6"	Vis hex. 1/2-20 x 6"	1
15	390 4025 00	Rivet	Rivet	1
16	222 0816 65	Hex Screw M8 x 1.25 x 16	Vis hex. M8 x 1.25 x 16	1
17	224 7811 40	Lock Washer	Rondelle-frein	1
18	732 6000 02	Self Tapping Screw M6 x 16	Vis autotaraudeuse M6 x 16	6
19	504 1243 00	Brake Disk	Disque de frein	1
20	504 1410 00	Fixed Pulley	Demi-poulie fixe	1
21	504 1120 00	Shim	Cale	@
22	504 1082 00	Shim	Cale	@
23→27	504 1380 00	Sliding Pulley	Demi-poulie coulissante	1
24	414 6749 00	Bushing	Douille	1
25	414 7867 00	Bushing	Douille	1
26	732 6010 67	Hex Screw M5	Vis hex M5	3
27	399 9100 00	Washer	Rondelle	3
28	414 5099 00	Release Spring	Ressort de rappel	1
29→30	504 0874 00	Outer Cam Ass'y	Came extérieure ass.	1
30	414 6803 00	Cam Slider Shoe	Glissière de came	3
31	372 9005 00	Dowel Pin	Goupille à ressort	1
32	504 0039 00	Spacer	Entretoise	1
33→34	580 5930 00	Driven Pulley Support	Support de poulie menée	1
34	405 4010 00	Ball Bearing	Roulement à billes	1
35	228 0810 45	Nut M8	Écrou M8	1
36	570 0283 00	Rod Retainer	Tide de retenue	1
37	414 5616 00	Spec Decal	Décalque de spécification	1

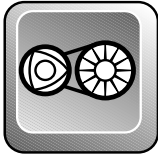

Pulleys Poulies

TUNDRA II LT

38	414 3136 00	Maintenance Decal	Décalque de maintenance	1
39	414 8276 00	Drive Belt	Courroie d'entraînement	1
40	414 8318 00	Spring	Ressort	1
41	391 3008 00	Washer	Rondelle	1
42	861 7434 00	High Altitude Kit (Not Shown)	Ens. haute altitude (non ill.)	1
43	517 0787 00	Washer	Rondelle	1

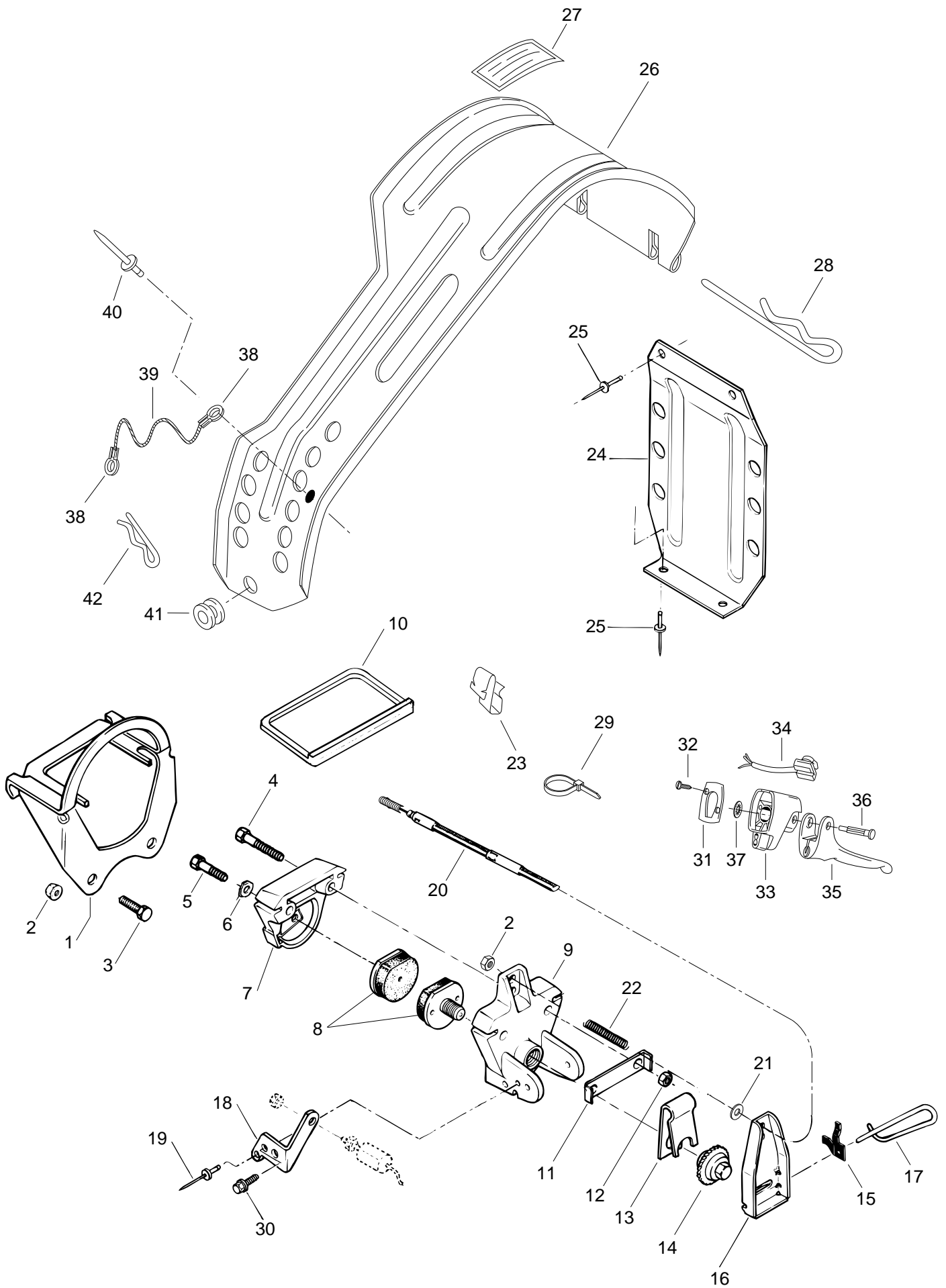



Brake and Belt Guard

Frein et garde-courroie

TUNDRA II LT

1	507 0270 00	Brake Support	Support de frein	1
2	228 5610 45	Elastic Nut M6 x 1.00	Écrou élastique M6 x 1.00	3
3	222 0620 65	Hex Screw M6 x 20	Vis hex. M6 x 20	2
4	222 0850 65	Hex Screw M8 x 1.25 x 50	Vis hex. M8 x 1.25 x 50	2
5	222 0514 65	Hex Screw M5 x .80 x 14	Vis hex. M5 x .80 x 14	1
6	507 0236 00	Lock Tab	Attache de verrouillage	1
7	414 4668 00	Anvil	Enclume	1
8	860 7001 00	Brake Lining Kit	Ens. de garnitures de frein	1
9	507 0266 00	Mobile Brake Lining Holder	Étrier de garniture de frein mobile	1
10	572 0135 00	Slider	Coulisse	1
11	507 0204 00	Lock Tab	Attache de verrouillage	1
12	228 5810 45	Elastic Hex Nut M8 x 1.25	Écrou élastique M8 x 1.25	2
13	507 0202 00	Release Spring	Ressort de rappel	1
14	507 0196 00	Ratchet Wheel	Roue à cliquet	1
15	507 0094 00	Pawl	Cliquet	1
16	507 0215 00	Brake Lever	Levier de frein	1
17	507 0275 00	Pin	Goupille de sûreté	1
18	507 0267 00	Stop Light Switch Support	Support de contacteur du feu d'arrêt	1
19	390 4023 00	Rivet	Rivet	1
20	414 9208 00	Brake Cable & Housing	Câble et gaine de frein	1
21	371 9013 00	Circlip	Circlip	1
22	414 4606 00	Spring	Ressort	1
23	414 2273 00	Clip	Pince	1
24	— XXX —	Rear Belt Guard	Garde-courroie arrière	1
25	390 4024 00	Rivet	Rivet	4
26	517 2463 00	Pulley Guard	Garde-poulies	1
27	414 1087 00	Warning Decal	Décalque d'avertissement	1
28	517 1646 00	Wave Pin	Goupille ondulée	1
29	414 1152 00	Tie-Rap	Attache	1
30	309 9045 00	Hex Self Tapping Screw	Vis hex.autotaraudeuse	1
31	572 0662 00	Cover	Couvercle	1
32	732 6030 01	Self Tapping Screw M3 x 16	Vis autotaraudeuse M3 x 16	2
33	572 0676 00	Brake Handle Housing	Logement de manette de frein	1
34	410 2093 00	Dimmer Switch	Commutateur d'éclairage	1
35	572 0666 00	Brake Handle	Manette de frein	1
36	414 1792 00	Pin	Goupille	1

Parts marked with «XXX» are not available as spare parts.

Les articles marqués d'un «XXX» ne sont pas disponibles comme pièces de remplacement.

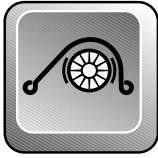

Brake and Belt Guard Frein et garde-courroie

TUNDRA II LT

37	389 8043 00	Push Nut	Écrou de blocage	1
38	561 5028 00	Ring Terminal	Cosse à anneau	2
39	414 4074 00	Wire	Fil métallique	1
40	390 4036 00	Rivet	Rivet	1
41	414 0363 00	Grommet	Passe-fils	1
42	414 5756 00	Secure Pin	Goupille de sûreté	1

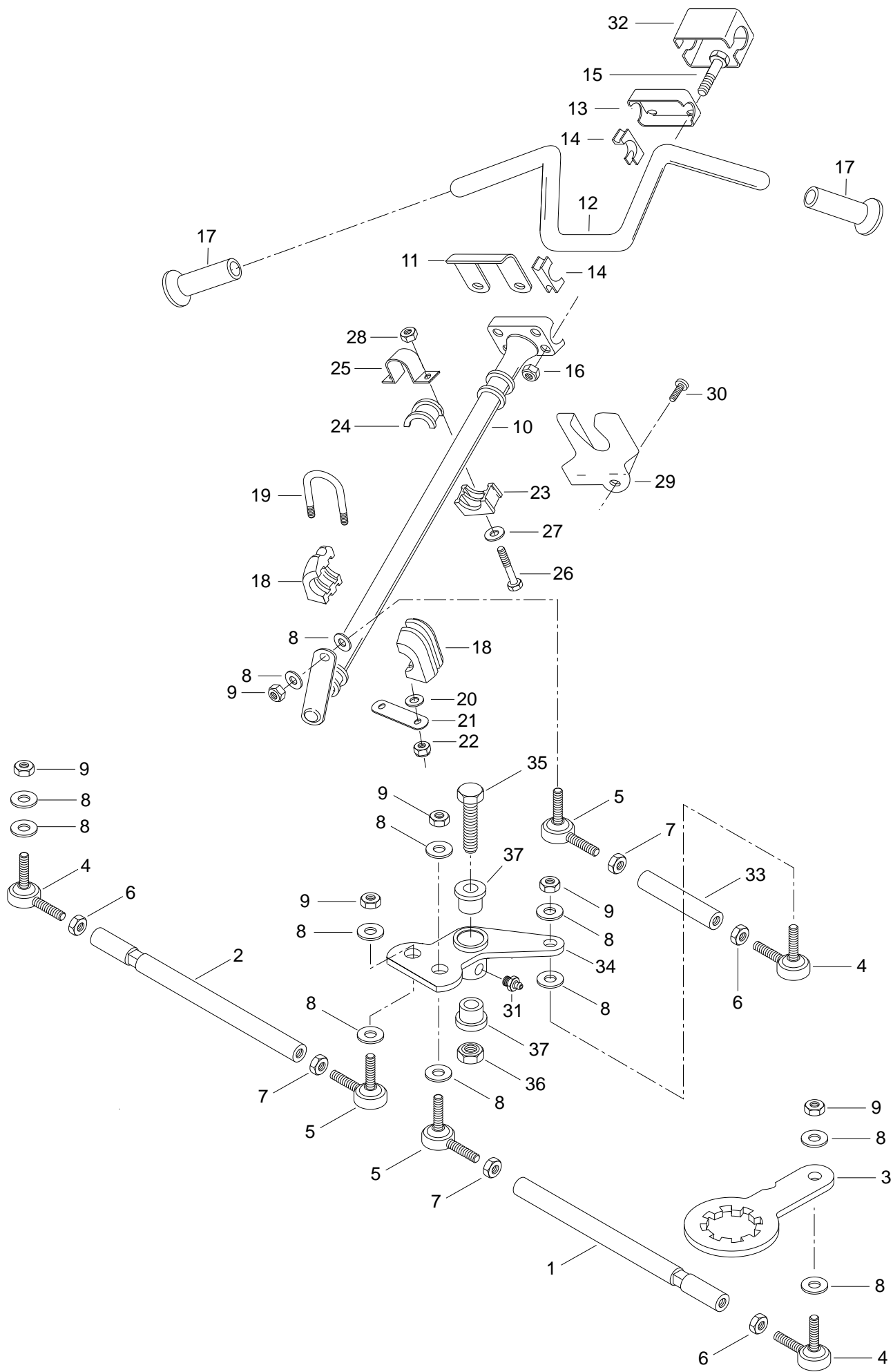



Steering System Système de direction

TUNDRA II LT

1	506 1133 00	Tie Rod	Barre d'accouplement	1
2	506 1134 00	Tie Rod	Barre d'accouplement	1
3	506 1218 00	Steering Arm	Bras de direction	2
4	414 7680 00	R.H. Ball Joint	Joint à rotule droit	3
5	414 7681 00	L.H. Ball Joint	Joint à roule gauche	3
6	732 6100 10	Jam Nut M10	Écrou de blocage M10	3
7	732 6100 11	Jam Nut M10	Écrou de blocage M10	3
8	503 1259 00	Hardened Washer	Rondelle trempée	12
9	732 6100 42	Elastic Nut M10	Écrou élastique M10	6
10	506 1136 00	Main Tube	Arbre de direction	1
11	517 2242 00	Retaining Support	Support de retenue	1
12	506 1159 00	Handle Bar	Guidon	1
13	506 0554 00	Steering Clamp	Bride de direction	1
14	414 4916 00	Steering Support	Support de guidon	4
15	222 0855 65	Hex Screw M8 x 55	Vis hex. M8 x 55	4
16	228 5810 45	Elastic Nut M8	Écrou élastique M8	4
17	572 0617 00	Handle Grip	Gaine de poignée	2
18	572 0671 00	Half Bushing	Demi-douille	2
19	506 0606 00	U-Clamp	Bride en U	1
20	224 0811 71	Washer 8 mm	Rondelle 8 mm	2
21	517 1347 00	Lock Tab	Patte de verrouillage	1
22	228 5810 45	Elastic Nut M8	Écrou élastique M8	2
23	572 0644 00	Lower Bushing	Douille (moitié inférieure)	1
24	572 0645 00	Upper Bushing	Douille (moitié supérieure)	1
25	517 1262 00	Retaining Support	Support de retenue	1
26	222 0820 65	Hex Screw M8 x 20	Vis hex. M8 x 20	2
27	224 0811 71	Washer 8 mm	Rondelle 8 mm	2
28	228 5810 45	Elastic Nut M8	Écrou élastique M8	2
29	517 2620 00	Plate	Plaque	1
30	364 9016 00	Metal Screw	Vis à métaux	1
31	408 2007 00	Grease Fitting	Graisseur	1
32	572 0669 00	Steering Cover	Couvercle de guidon	1
33	506 1138 00	Tie Rod	Barre d'accouplement	1
N 34	506 1180 00	Pivot Arm	Bras de renvoi	1
35	222 0065 65	Hex Screw M10 x 65	Vis hex. M10 x 65	1
36	228 5010 45	Elastic Nut M10	Écrou élastique M10	1
37	414 5300 00	Cushion	Coussinet	2

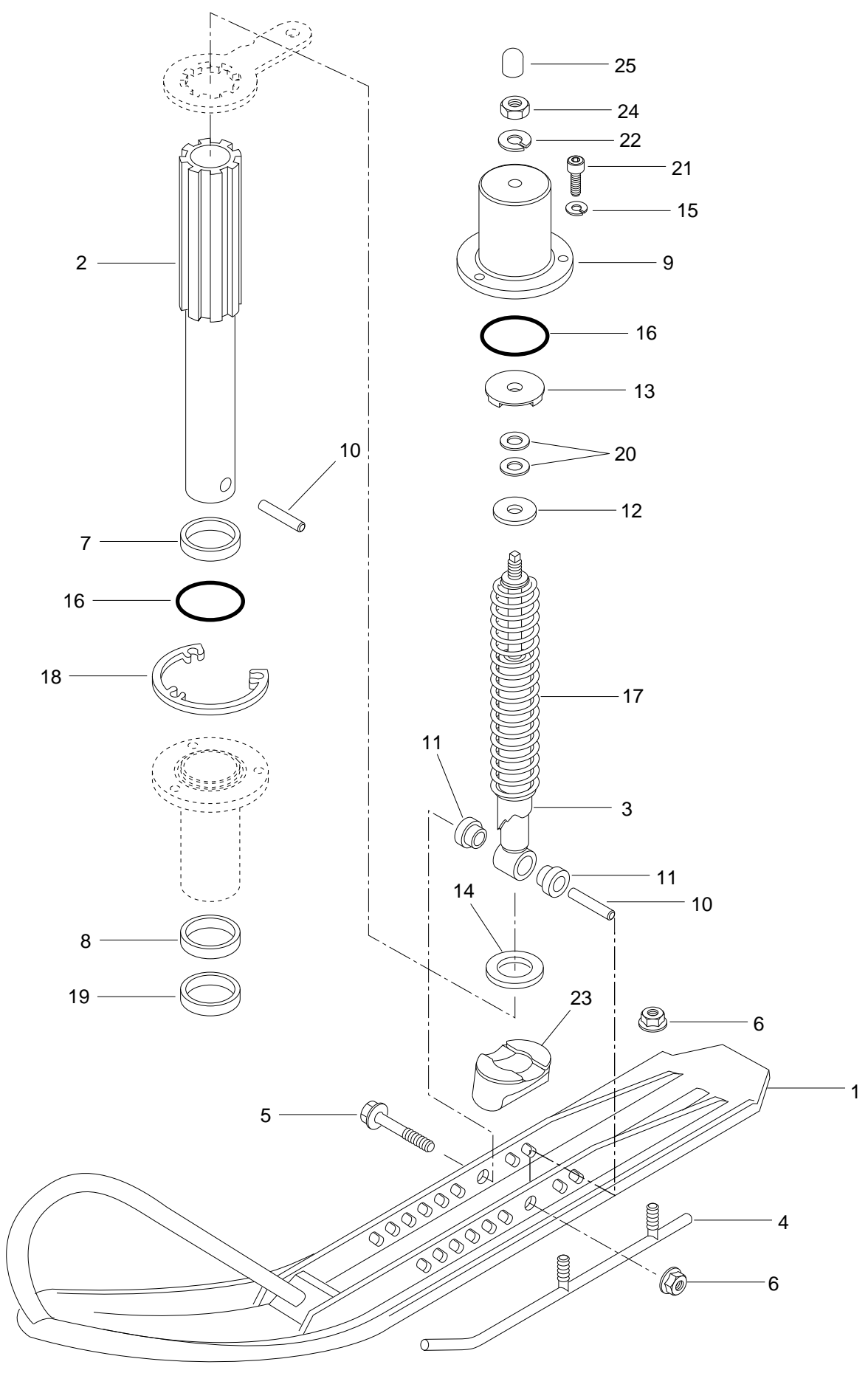



Front Suspension and Ski Suspension avant et ski

TUNDRA II LT

1	505 0653 00	Ski	Ski	2
2	506 1217 00	Ski Leg	Jambe de ski	2
3	414 8036 00	Shock	Amortisseur	2
4	505 0654 00	Runner	Lisse	2
	505 0648 00	Carbide Runner	Lisse au carbure	Opt
5	222 0090 65	Hex Screw M10 x 90	Vis hex. M10 x 90	2
6	228 5010 45	Elastic Nut M10	Écrou élastique M10	6
7	414 8031 00	Upper Cushion	Coussinet supérieur	2
8	414 8032 00	Lower Cushion	Coussinet inférieur	2
9	518 2032 00	Cover	Couvercle	2
10	503 1564 00	Bushing	Douille	2
11	572 0345 00	Cushion	Coussinet	4
12	518 2034 00	Washer	Rondelle	2
13	570 0258 00	Stopper	Butée	2
14	518 2047 00	Washer	Rondelle	2
15	224 7811 40	Lock Washer 8 mm	Rondelle-frein 8 mm	6
16	414 8114 00	O-Ring	Joint torique	4
17	414 8030 00	Spring	Ressort	2
18	503 1456 00	Spacer	Entretoise	2
19	414 8089 00	Seal	Joint étanche	2
20	224 0012 11	Washer	Rondelle	4
21	222 9820 65	Allen Screw M8 x 20	Vis Allen M8 x 20	6
22	224 7011 70	Lock Washer 10 mm	Rondelle-frein 10 mm	2
23	570 0270 00	Stopper	Butée	2
24	228 0010 45	Nut M10	Écrou M10	2
25	414 8771 00	Cap	Capuchon	2

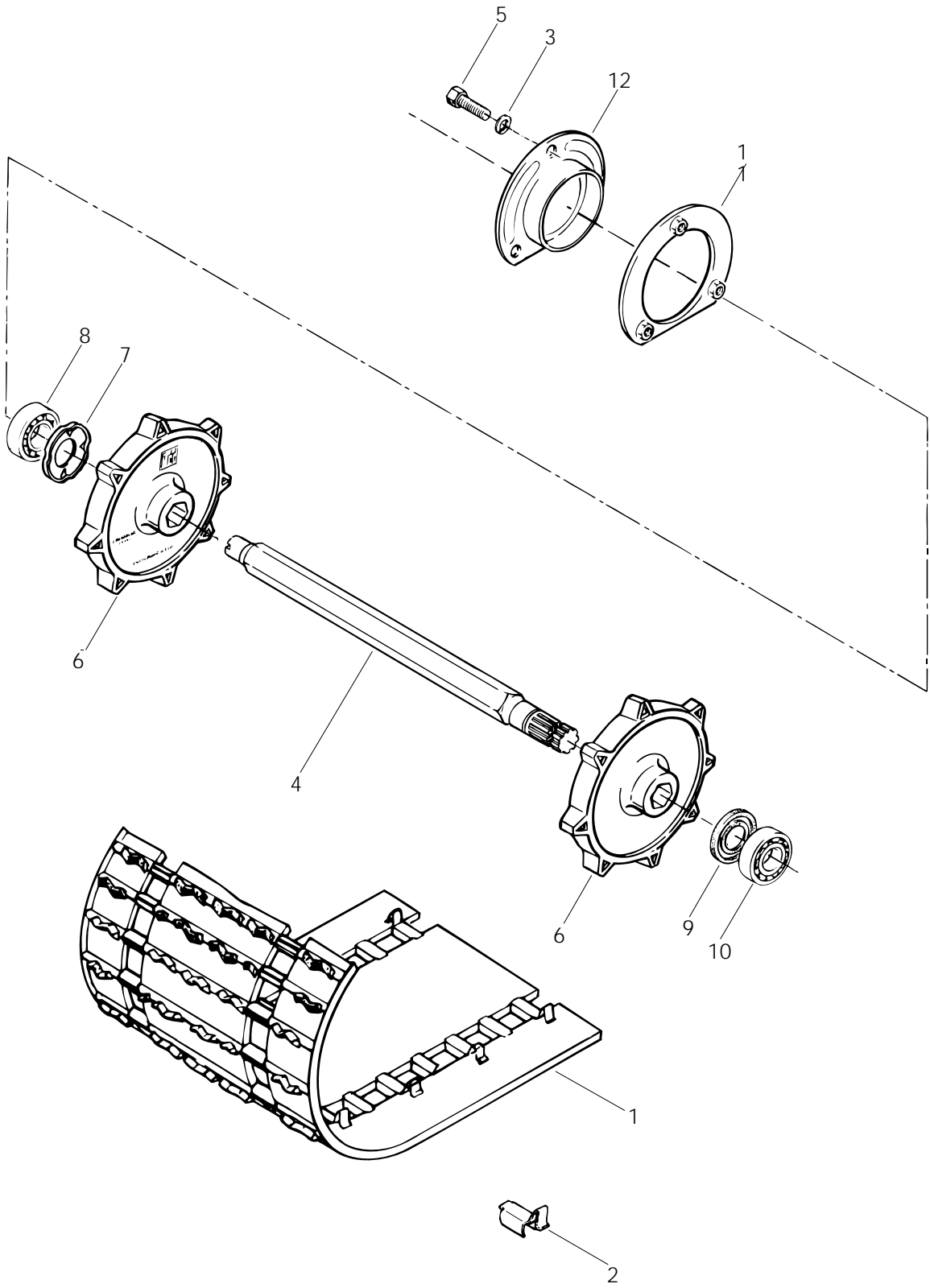



Drive Axle and Track Essieu moteur et chenille

TUNDRA II LT

1	570 2060 00	Track	Chenille	1
2	500 0027 00	Guide	Guide	142
3	224 7611 10	Lock Washer 6 mm	Rondelle-frein 6 mm	3
4	501 0209 00	Drive Axle	Arbre d'entraînement	1
5	222 0616 65	Hex Screw M6 x 16	Vis hex. M6 x 16	3
6	414 6159 00	Sprocket 8 Teeth	Barbotin 8 dents	2
7	501 0174 00	Bearing Protector	Protecteur de roulement	1
8	405 4045 00	Ball Bearing	Roulement à billes	1
9	581 1017 00	Seal	Anneau d'étanchéité	1
10	405 4044 00	Ball Bearing 6205	Roulement à billes 6205	1
11	501 0152 00	Retainer Ring	Segment de retenue	1
12	501 0195 00	End Bearing Housing	Logement de roulement à billes	1

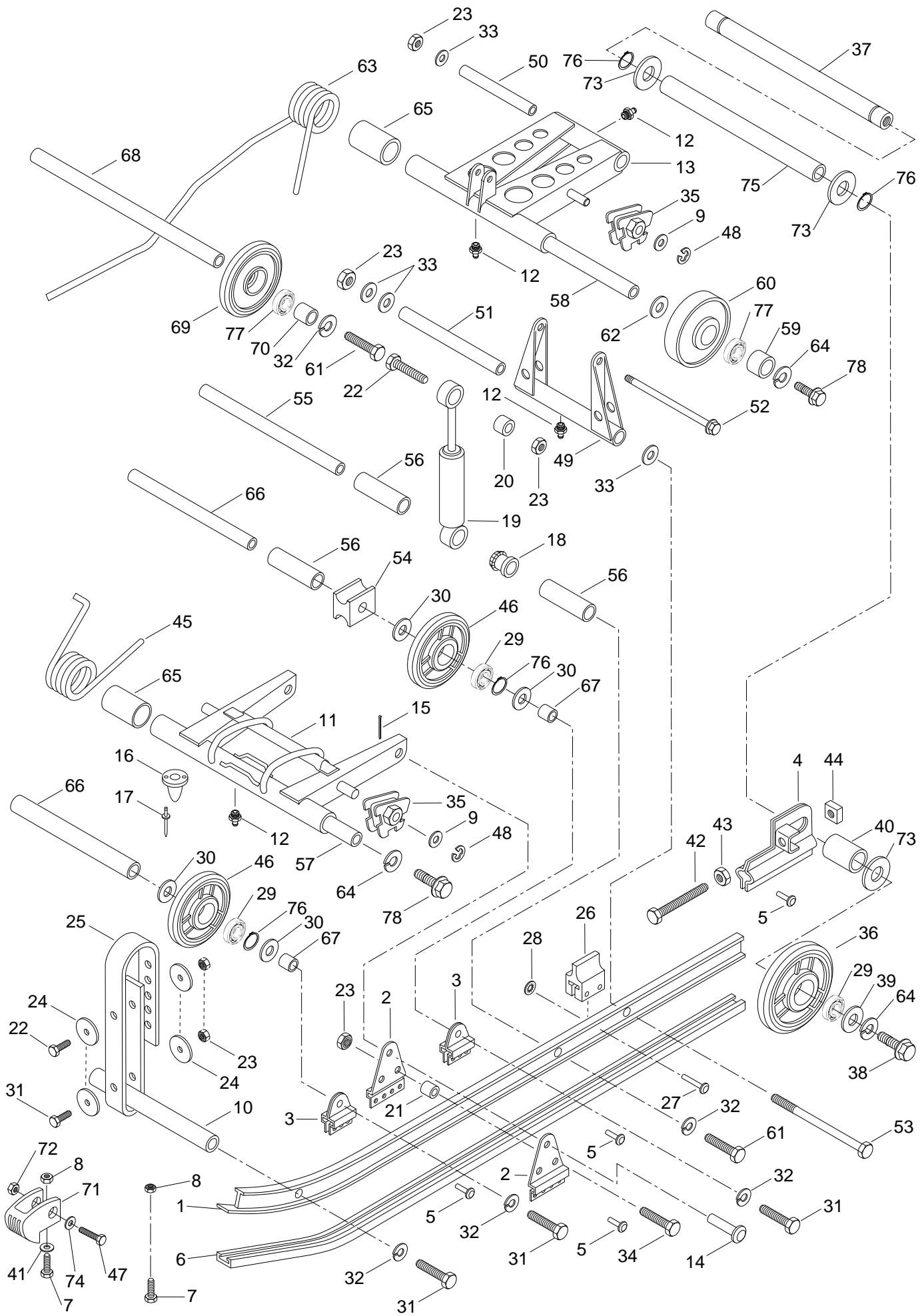



Rear Suspension Suspension arrière

TUNDRA II LT

1	503 1617 00	Runner	Porte-glissière	2
2	503 1498 00	Front Arm Support	Support du bras avant	4
3	503 1450 00	Support	Support	8
4	503 1614 00	R.H. Adjustment Plate	Plaque de réglage droite	1
	503 1615 00	L.H. Adjustment Plate	Plaque de réglage gauche	1
5	390 9062 00	Rivet	Rivet	28
6	560 3144 00	Slider Shoe	Glissière	2
7	222 0530 65	Hex Screw M5 x 30	Vis hex. M5 x 30	2
8	228 7510 45	Elastic Nut M5	Écrou élastique M5	2
9	224 0012 11	Washer	Rondelle	4
10	503 1434 00	Cross-Shaft	Axe transversal	1
11	503 1453 00	Front Arm	Bras avant	1
12	408 2007 00	Grease Fitting	Graisseur	4
13	503 1435 00	Rear Arm	Bras arrière	1
14	414 1915 00	Clevis Pin	Axe à goupille	2
15	371 8002 00	Cotter Pin	Goupille fendue	2
16	570 0329 00	Front Rubber Stopper	Butée de caoutchouc avant	2
17	390 4020 00	Rivet	Rivet	4
18	572 0307 00	Bushing Clip	Douille autofreinée	1
19	414 8021 00	Shock	Amortisseur	1
20	414 8026 00	Cushion	Coussinet	1
21	503 0383 00	Spacer	Entretoise	2
22	222 0835 65	Hex Screw M8 x 35	Vis hex. M8 x 35	2
23	228 5810 45	Elastic Nut M8	Écrou élastique M8	7
24	517 0787 00	Washer	Rondelle	4
25	570 0257 00	Stopper Strap	Courroie d'arrêt	1
N 26	570 0479 00	Rear Rubber Stopper	Butée de caoutchouc arrière	2
27	390 0048 00	Rivet	Rivet	4
28	389 8043 00	Push Nut	Contre-écrou	4
29	405 4045 00	Ball Bearing 6205	Roulement à billes 6205	6
30	414 9192 00	Cushion	Coussinet	8
31	222 0830 65	Hex Screw M8 x 30	Vis hex. M8 x 30	7
32	224 7811 40	Lock Washer 8 mm	Rondelle-frein 8 mm	10
33	224 0811 71	Washer	Rondelle	7
34	222 0840 65	Hex Screw M8 x 40	Vis hex. M8 x 40	2
35	572 0309 00	Adjustment Cam R.H.	Came de réglage droit	2
	572 0308 00	Adjustment Cam L.H.	Came de réglage gauche	2
36	570 0443 00	Idle Wheel 155	Roue de support 155	2



Rear Suspension Suspension arrière

TUNDRA II LT

37	503 1624 00	Rear Axle	Essieu arrière	1
38	732 6010 02	Hex Screw M10 x 35	Vis hex. M10 x 35	2
39	503 1643 00	Washer	Rondelle	2
40	503 1610 00	Bushing	Douille d'écartement	2
41	517 2259 00	Washer	Rondelle plate	2
42	732 6010 03	Hex Adjustment Screw M10 x 75	Vis de réglage hex. M10 x 75	2
43	228 0010 45	Nut M10	Écrou M10	2
44	732 6100 59	Square Nut M10	Écrou carré M10	2
45	414 8804 00	R.H. Spring	Ressort droit	1
	414 8805 00	L.H. Spring	Ressort gauche	1
46	570 0140 00	Idler Wheel 135	Roue de support 135	4
47	222 0630 65	Hex Screw M6 x 30	Vis hex. M6 x 30	2
48	371 9071 00	Circlip	Circlip	4
49	503 1441 00	Pivot Arm	Jumelle	1
50	503 1443 00	Upper Axle	Axe supérieur	1
51	503 1444 00	Lower Axle	Axe inférieur	1
N 52	732 6011 97	Bolt M8 (Short)	Boulon M8 (court)	1
N 53	732 6011 98	Bolt M8 (Long)	Boulon M8 (long)	1
54	572 0343 00	Spring Support	Appui ressort	2
55	503 1445 00	Cross Shaft	Axe transversal	1
56	572 0356 00	Plastic Bushing	Douille de plastique	3
57	503 1446 00	Front Cross Shaft	Axe transversal avant	1
58	503 1447 00	Rear Cross Shaft	Axe transversal arrière	1
59	503 1448 00	Spacer	Entretoise	2
N 60	415 0056 00	Idler Wheel (Incl 77)	Roue de support (incl 77)	2
61	222 0825 65	Hex Screw M8 x 25	Vis hex. M8 x 25	4
62	503 1449 00	Washer	Rondelle	2
63	414 8802 00	R.H. Spring	Ressort droit	1
	414 8803 00	L.H. Spring	Ressort gauche	1
64	224 7011 88	Lock Washer 10 mm	Rondelle-frein 10 mm	6
65	572 0394 00	Bushing	Douille	6
66	503 1451 00	Center Axle	Essieu central	2
67	503 1442 00	Spacer	Entretoise	4
68	503 0956 00	Cross Shaft	Axe transversal	1
69	572 0354 00	Idler Wheel (Incl 77)	Roue de support (incl 77)	2
70	503 0827 00	Spacer	Entretoise	2
71	572 0540 00	Protector Runner	Protecteur-rail	2
72	228 7610 45	Flanged Elastic Nut M6	Écrou élastique à épaulement M6	2



Rear Suspension Suspension arrière

TUNDRA II LT

73	504 1082 00	Spacer	Entretoise	4
74	224 0611 21	Flat Washer	Rondelle Plate	2
75	503 1620 00	Center Spacer	Entretoise centrale	1
76	371 9017 00	Circlip	Circlip	6
77	405 4046 00	Ball Bearing 6202	Roulement à billes 6202	4
78	222 0035 65	Hex Screw M10 x 35	Vis hex M10 x 35	4

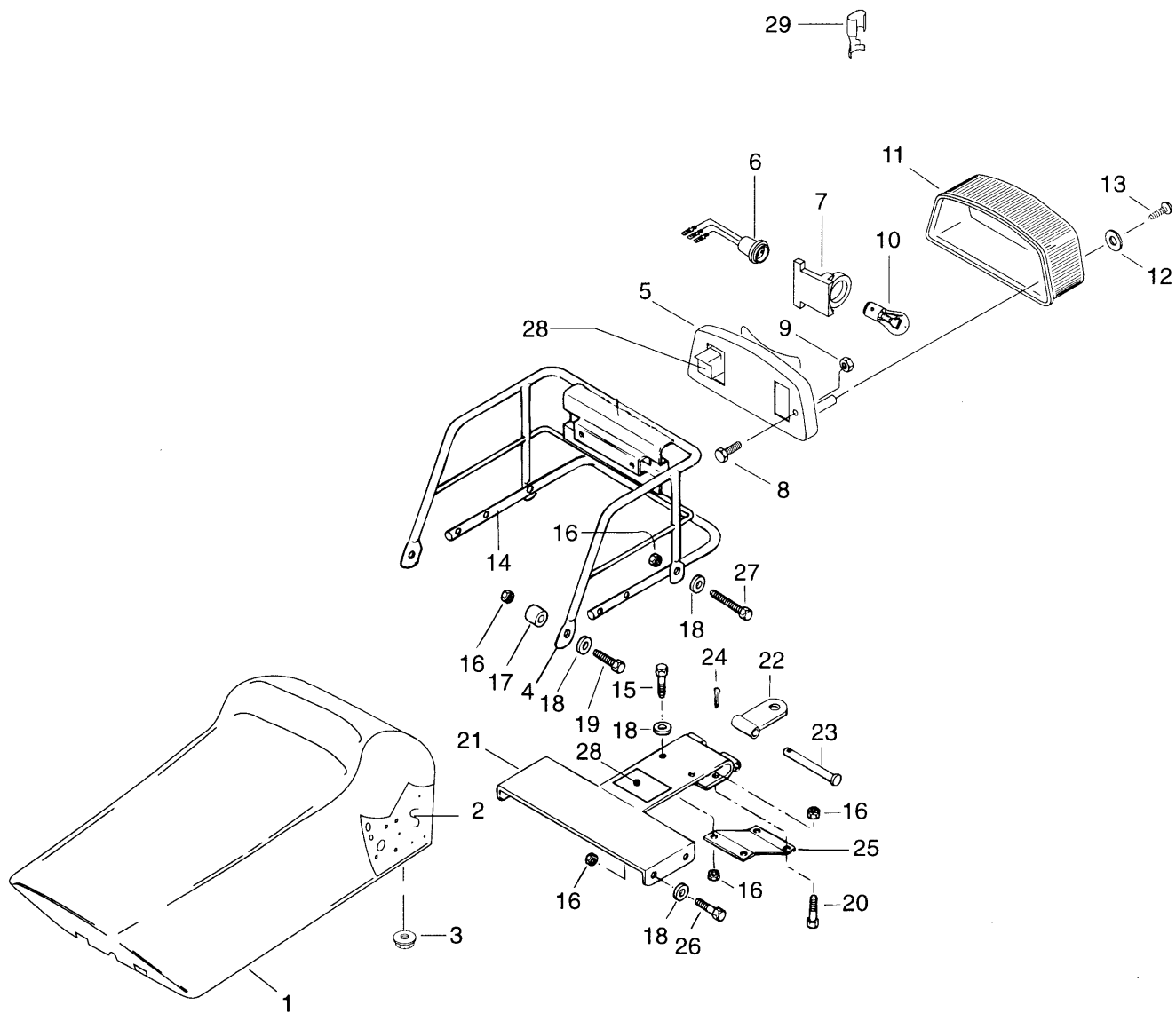



Frame and Body Châssis et carrosserie

TUNDRA II LT

1	414 9317 02	Seat Cover	Housse de siège	1
2	414 7371 00	Formed Foam Seat	Caoutchouc mousse de siège formé.....	1
3	228 7610 45	Flanged Nut M6	Écrou à épaulement M6	2
4	517 1915 00	Rack	Porte-bagages	1
N 5→7	414 9794 00	Taillamp Housing	Boîtier du feu arrière	1
N 6	414 9794 10	Socket	Raccord	1
N 7	414 9794 11	Rubber Damper	Amortisseur	1
8	222 0525 65	Hex Screw M5 x 25	Vis hex. M5 x 25	2
9	228 7510 45	Nut M5	Écrou M5	2
10	410 5040 00	Bulb	Ampoule	1
11	414 5137 00	Lens	Lentille	1
12	414 5164 00	Plastic Washer	Rondelle de plastique	2
13	414 5163 00	Phillips Screw	Vis cruciforme	2
14	517 1707 00	Rear Bumper	Pare-chocs arrière	1
15	222 0625 65	Hex Screw M6 x 25	Vis hex. M6 x25	2
16	228 7610 45	Elastic Nut M6	Écrou élastique M6	12
17	517 1856 00	Spacer	Entretoise	4
18	224 0611 21	Washer 6.4 mm	Rondelle 6.4 mm	10
19	222 0635 65	Hex Screw M6 x 35	Vis hex. M6 x 35	2
20	222 0620 65	Hex Screw M6 x 20	Vis hex. M6 x 20	2
21	517 2006 00	Hitch Bracket	Support d'attelage	1
22	517 0087 00	Hitch Plate	Plaque d'attelage	1
23	505 0017 00	Pin	Axe de goupille	1
24	371 8002 00	Cotter Pin	Goupille fendue	1
25	517 2178 00	Reinforcement	Renfort	1
26	222 0640 65	Hex Screw M6 x 40	Vis hex. M6 x 40	4
27	— XXX —	Hex Screw M6 x 60	Vis hex. M6 x 60	2
28	572 1508 00	Block Dimmer Switch	Bloc inverseur	1
29	561 5031 00	Female Connector	Raccord femelle	@
N 30	414 9985 00	Label-Instruction	Étiquette d'instruction	1

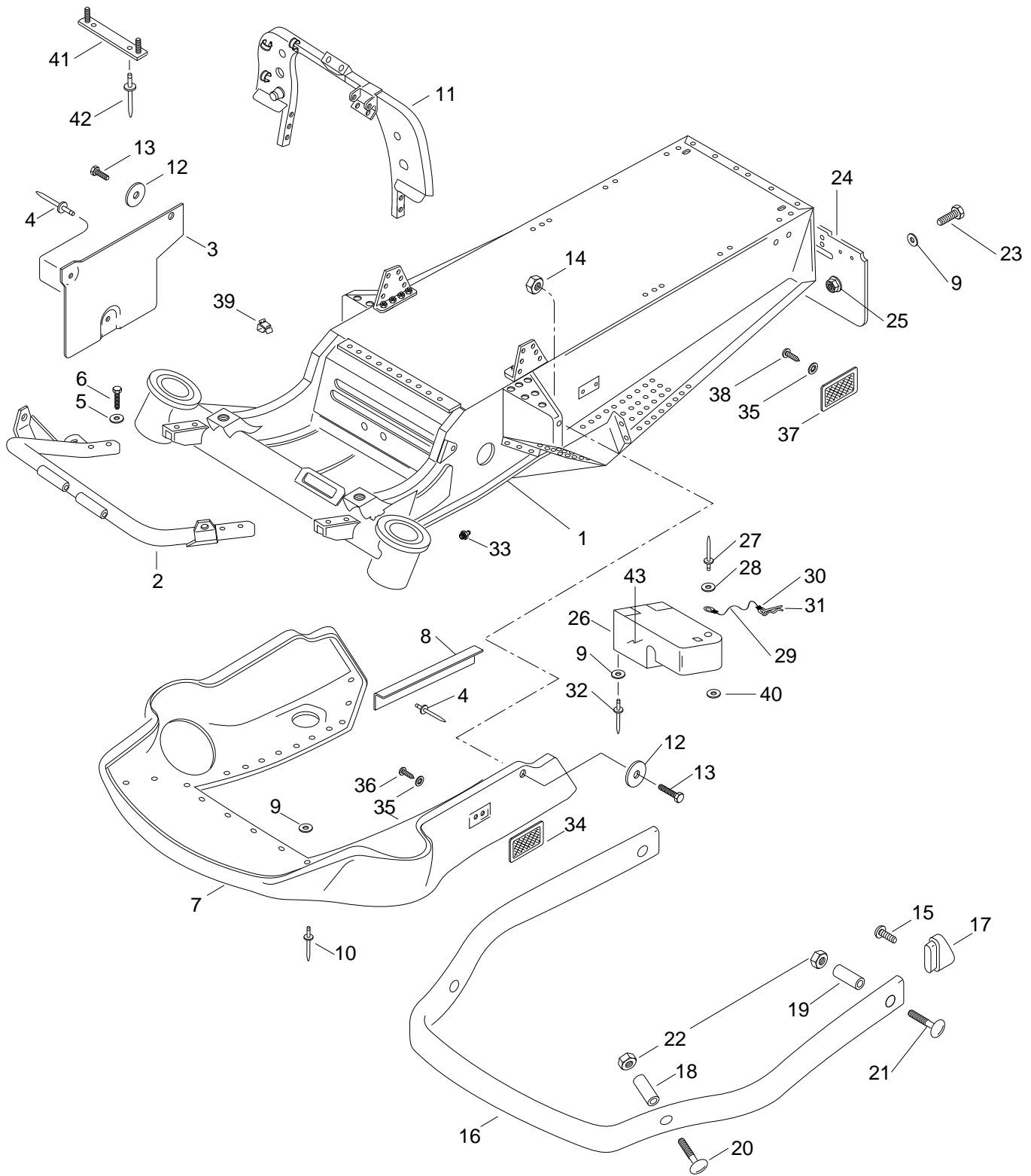



Frame and Body

Châssis et carrosserie

TUNDRA II LT

N 1	580 6397 00	Frame Ass'y	Châssis ass.	1
N 2	518 3124 00	Front Bumper	Pare-chocs avant	1
3	517 2516 00	Heat Shield	Écran thermique	1
4	390 4036 00	Rivet	Rivet	6
5	224 7611 10	Lock Washer 6 mm	Rondelle-frein 6 mm	4
6	222 0625 65	Hex Screw M6 x 25	Vis hex. M6 x 25	2
	222 0635 65	Hex Screw M6 x 35	Vis hex. M6 x 35	2
7	414 9209 00	Bottom Pan	Coque	1
8	517 2592 00	Bottom Pan Reinforcement	Renfort de coque	1
9	517 1243 00	Washer	Rondelle	11
10	390 4096 00	Rivet	Rivet	@
N 11	518 3116 00	Upper Column Support	Support de colonne de direction	1
12	224 0611 21	Washer 6,4 mm	Rondelle 6,4 mm	2
13	222 0616 65	Hex Screw M6 x 16	Vis hex. M6 x 16	2
14	228 5610 45	Elastic Nut M6	Écrou élastique M6	2
15	222 6410 60	Self Tapping Screw	Vis autotaraudeuse	2
16	517 2488 10	Front Bumper	Pare-chocs avant	1
17	572 0393 00	Bumper Cap	Capuchon de pare-chocs	2
18	517 2506 00	Bushing	Douille	2
19	517 2507 00	Bushing	Douille	2
20	222 2875 65	Carriage Bolt M8 x 75	Vis de carrosserie M8 x 75	2
21	222 2855 65	Carriage Bolt M8 x 55	Vis de carrosserie M8 x 55	2
22	228 5810 45	Elastic Nut M8	Écrou élastique M8	4
23	222 0520 65	Hex Screw M5 x 20	Vis hex. M5 x 20	4
24	572 0138 00	Snow Guard	Garde-neige	1
25	228 7510 45	Elastic Flanged Nut M5	Écrou élastique à épaulement M5	4
26	414 6249 00	Tool Box	Coffre à outils	1
27	390 4017 00	Rivet	Rivet	1
28	391 3010 00	Washer	Rondelle	1
29	414 4074 00	Wire	Fil métallique	1
30	561 5028 00	Ring Terminal	Cosse à anneau	2
31	414 5756 00	Wave Pin	Goupille ondulée	1
32	390 9068 00	Rivet	Rivet	3
33	408 2007 00	Grease Fitting	Graisser	2
34	414 5102 00	Amber Reflector	Réfecteur ambre	2
35	224 1511 01	External Tooth Lock Washer M5	Rondelle-frein à dents ext. M5	4



Frame and Body Châssis et carrosserie

TUNDRA II LT

36	222 8510 65	Phillips Screw M5 x 10	Vis cruciforme M5 x 10	2
37	414 5101 00	Red Reflector	Rélecteur rouge	2
38	222 8508 65	Phillips Screw M5 x 8	Vis cruciforme M5 x 8	2
39	414 2273 00	Clip	Pince	3
40	224 0611 21	Washer 6.4 mm	Rondelle 6.4 mm	1
N 41	517 2788 00	Retainer Plate	Plaque de retenue	1
42	390 4024 00	Rivet	Rivet	2
43	529 0286 00	Kit-Tool	Trousse d'outils	1
	529 0148 00	Wrench Socket 21/26 mm	Clé a douille 21/26 mm	1
	529 0192 00	Screw Driver	Tournevis	1
	529 0149 00	Wrench Socket 10/13 mm	Clé a douille 10/13 mm	1
	412 5001 00	Rope-Starter	Corde de démarrage	1
	529 0244 00	Adaptor-Rope	Adapteur de corde	1
	529 0173 00	Wrench-Fork 10/13 mm	Clé ouverte 10/13 mm	1
	529 0193 00	Wrench-Fork 15/17 mm	Clé ouverte 15/17 mm	1
	529 0147 00	Multiple Wrench	Clé Multiple	1

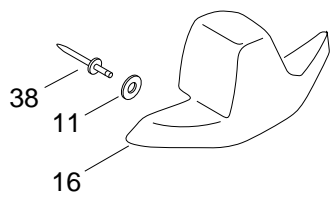
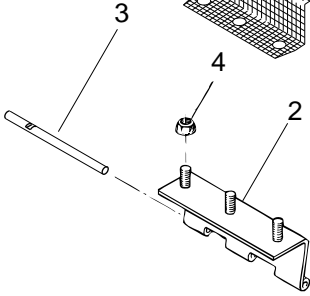
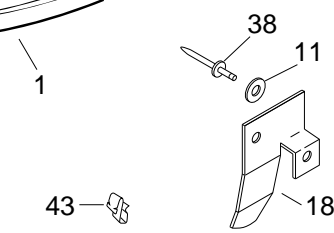
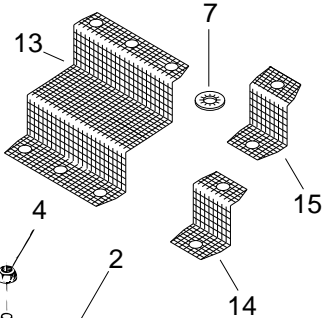
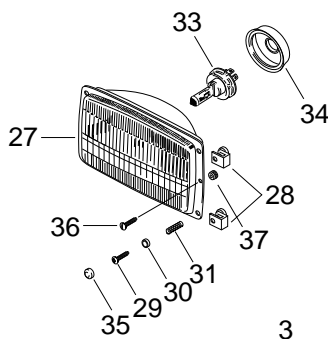
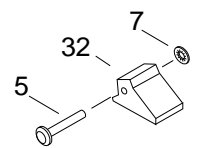
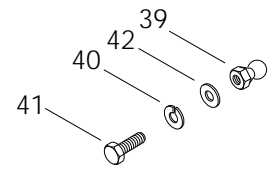
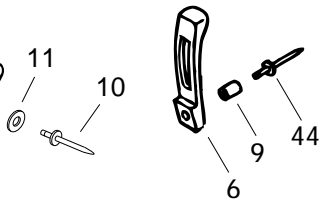
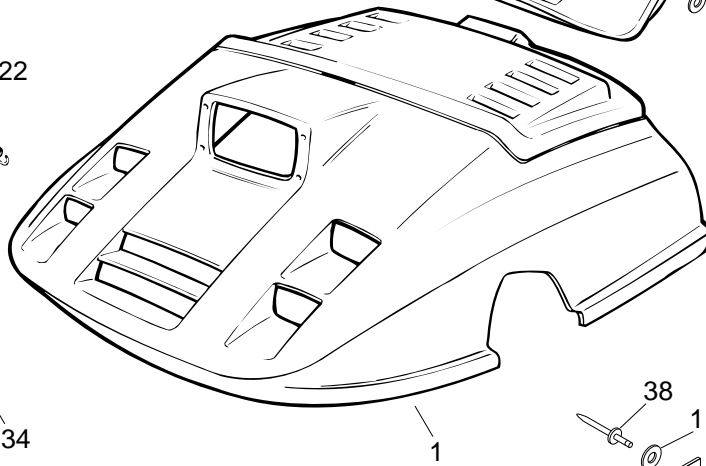
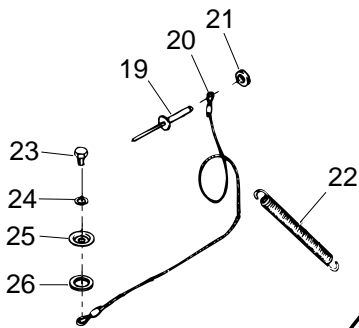
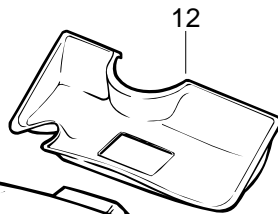
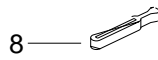
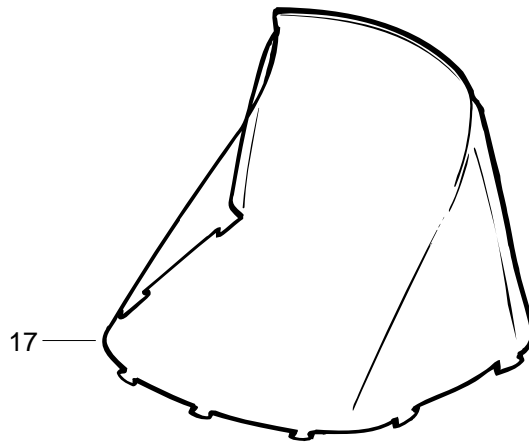



Frame and Body

Châssis et carrosserie

TUNDRA II LT

*1	572 0481 02	Hood	Capot	1
2	517 1822 00	Cab Hinge	Charnière de capot	1
N 3	517 2798 00	Pivot Axle	Axe de pivotement	1
4	228 7610 45	Flanged Nut M6	Écrou à épaulement M6	3
5	390 9070 00	Rivet	Rivet	2
6	570 0259 00	Hood Latch	Attache de capot	2
7	389 8043 00	Push Nut	Écrou à pression	@
8	570 0238 00	Windshield Latch	Attache de pare-brise	9
9	517 2459 00	Bushing	Douille	2
10	390 4004 00	Rivet	Rivet	4
11	517 2259 00	Washer	Rondelle	14
12	414 8040 00	Air Duct	Conduit d'air	1
13	517 2517 00	Center Front Grill	Grille avant centrale	1
14	517 2518 00	Lower Front Grill	Grille avant basse	2
15	517 2706 00	R.H Upper Front Grill	Grille avant haute DR	1
	517 2707 00	L H Upper Front Grill	Grille avant haute GA	1
16	572 0389 00	R.H. Cab Moulding	Enjoliveur de capot droit	1
	572 0388 00	L.H. Cab Moulding	Enjoliveur de capot gauche	1
17	414 8294 00	Windshield	Pare-brise	1
18	517 2613 00	R.H. Hood Guide	Guide de capot droit	1
	517 2515 00	L.H. Hood Guide	Guide de capot gauche	1
19	390 4096 00	Rivet	Rivet	1
20	414 5814 00	Cab Retainer Cable	Cable de retenue de capot	1
21	517 1243 00	Washer	Rondelle	1
22	414 7633 00	Spring	Ressort	1
23	222 0816 65	Hex Screw M8 x 16	Vis hex. M8 x 16	1
24	420 9457 52	Lock Washer M8	Rondelle-frein M8	1
25	420 8271 40	Cowl Cover	Couvercle de déflecteur	1
26	420 9608 65	Rubber Washer	Rondelle de caoutchouc	1
27	410 6068 00	Headlamp	Boîtier du phare	1
28	572 3787 00	Special Nut	Écrou spéciale	4
29	732 6030 02	Oval Phillips Screw M4 x 40	Vis ovale cruciforme M4 x 40	4
30	414 4368 00	Cap Retainer	Rondelle de retenue	4
31	517 1660 00	Spring	Ressort	4
32	570 0387 00	Guide-Hood	Guide capot	2
33	410 5037 00	Halogen Bulb	Ampoule halogène	1

*All labels must be ordered and installed when replacing cab.

*Tous les autocollants doivent être commandés et installés lorsqu'un capot est remplacé.



Frame and Body Châssis et carrosserie

TUNDRA II LT

34	410 6071 00	Protector Cap	Capuchon protecteur	1
35	414 7685 00	Yellow Snap Cap.....	Capuchon à pression jaune	4
36	410 6033 00	Slotted Screw	Vis fendue	2
37	410 6044 00	Grommet	Rondelle isolante	2
38	390 4072 00	Rivet	Rivet	@
39	517 2458 00	Button	Bouton	2
40	224 7510 90	Lock Washer 5 mm	Rondelle-frein 5 mm.....	2
41	222 0514 65	Hex Screw M5 x 14.....	Vis hex. M5 x 14	2
42	391 3017 00	Washer	Rondelle	2
43	414 0951 00	Clip	Pince	1
44	390 9068 00	Rivet	Rivet	2



8



9



6



4



7

TUNDRA II

2

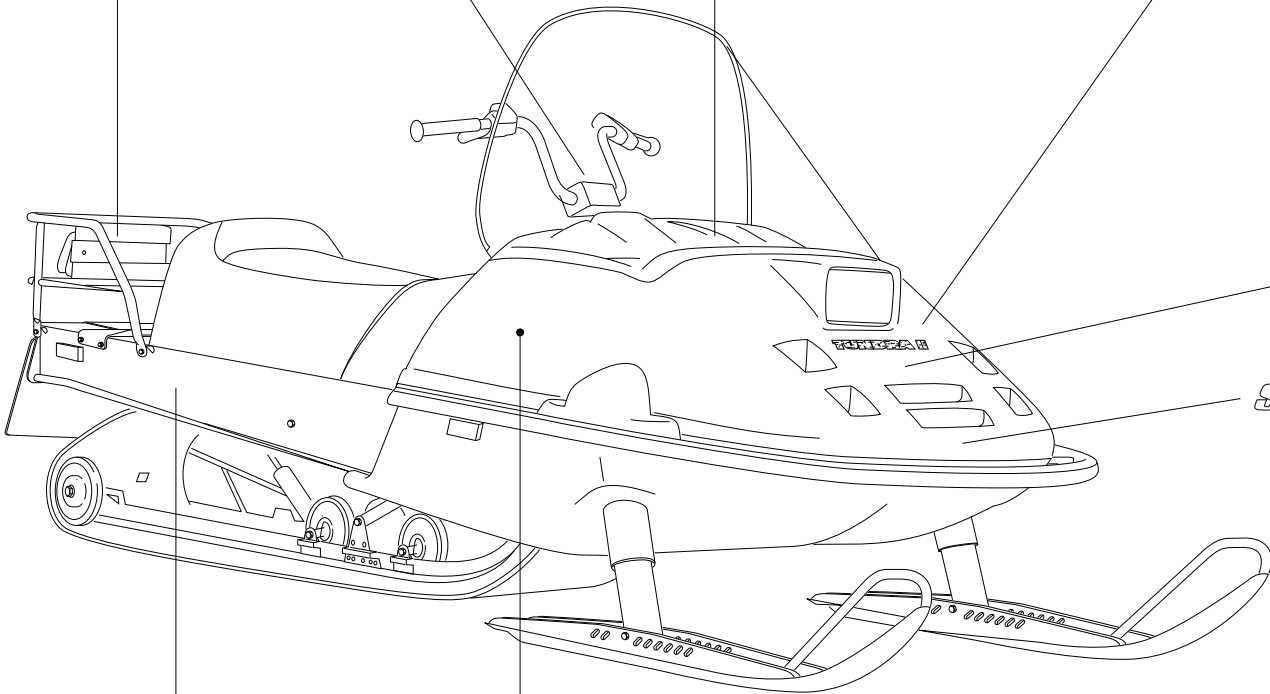

5



ski doo

10



1



3



Decal Décalcomanie

TUNDRA II LT

N 1	414 9751 00	Side Decal Kit (Hood)	Ens. de décalques latéraux (capot)	1
N 2	414 9929 00	Identification Decal	Décalque d'identification	1
N 3	414 9752 00	Stripe Decal Kit (Frame)	Ens. bande décorative (châssis)	Opt
4	414 7515 00	«BOMBARDIER» Decal	Décalque «BOMBARDIER»	1
N 5	414 9981 00	«BOMBARDIER» Logo	Logo «BOMBARDIER»	1
N 6	414 9985 00	Instruction Decal (Hitch)	Décalque d'instruction (attelage).....	1
N 7	414 9980 00	Warning Decal (Cab)	Décalque d'avertissement (capot)	1
8	414 1615 00	Warning Decal (Air Silencer)	Décalque d'avertissement (sil. d'adm)	1
9	414 1087 00	Warning Decal (Pulley Guard)	Décalque d'avert. (garde-poulies)	1
N 10	414 9982 00	«SKI-DOO» Decal	Décalque «SKI-DOO»	1

*All labels must be ordered and installed when replacing cab.

*Tous les autocollants doivent être commandés et installés lorsqu'un capot est remplacé.

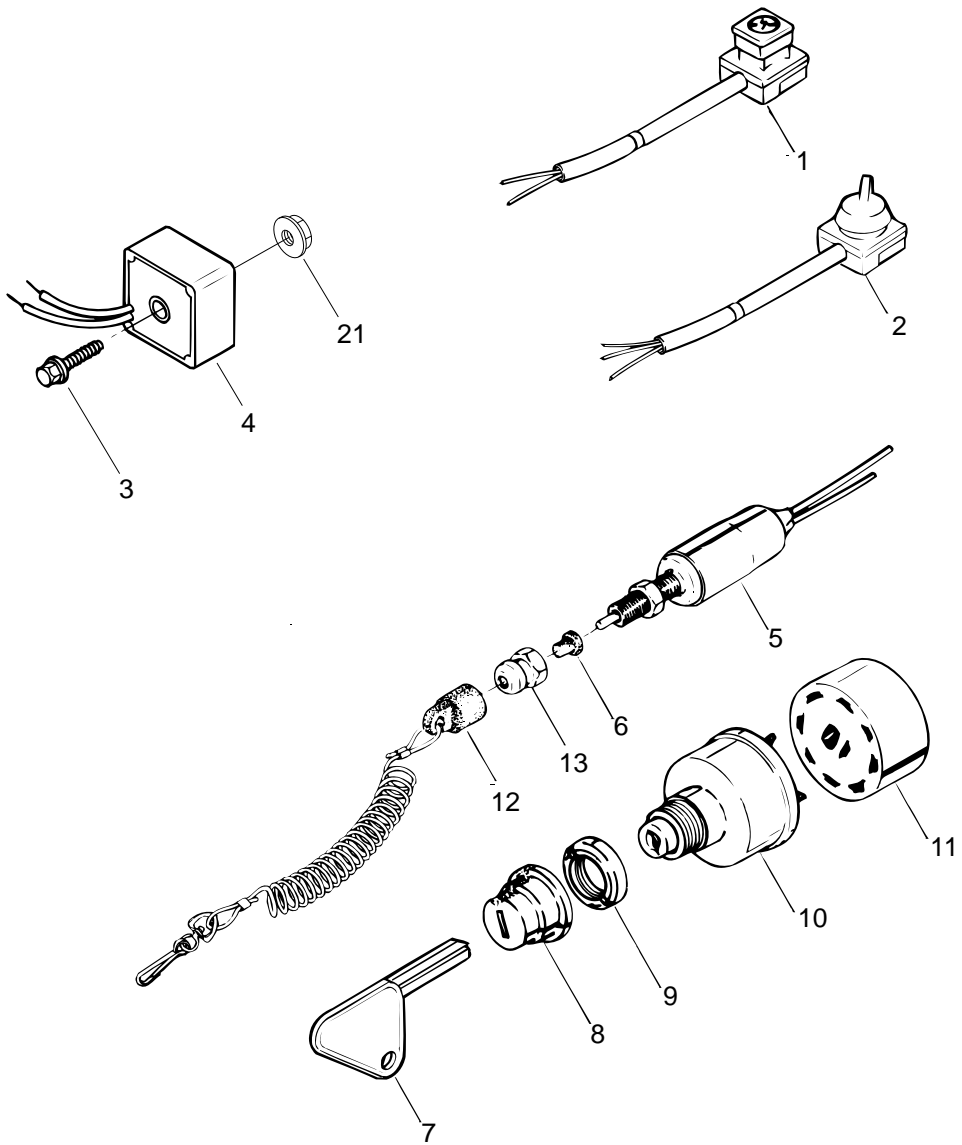
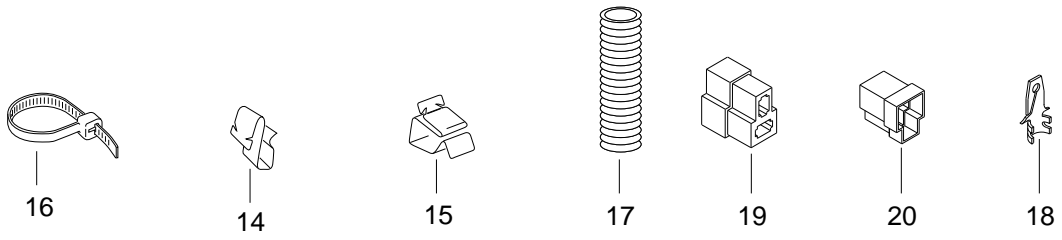

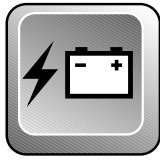

Electric System Système électrique

TUNDRA II LT

1	410 2094 00	Kill Switch	Interrupteur d'urgence	1
2	410 2093 00	Dimmer Switch	Commutateur d'éclairage	1
3	222 0635 65	Hex Screw M6 x 35	Vis hex. M6 x 35	1
4	410 1106 00	Voltage Regulator	Régulateur de tension	1
5	410 1067 00	Brake Switch	Interrupteur de frein	2
6	570 1511 00	Plunger Cap	Capuchon plongeur	1
7	414 0403 00	Key Blank (Metal)	Clé vierge (métal)	1
8	570 0137 00	Boot	Protecteur	1
9	410 1078 00	Face Nut	Écrou avant	1
10	410 1025 00	Ignition Switch	Interrupteur d'allumage	1
11	572 1507 00	Ignition Switch Block	Bloc de raccord	1
12	515 1515 00	Switch Cap	Capuchon	1
13	515 1459 00	Switch Nut	Écrou borgne	1
14	414 0951 00	Clip	Pince	@
15	414 2273 00	Clip	Pince	@
16	414 1152 00	Tie Rap	Attache	@
17	414 6124 00	Tubing	Gaine	@
18	561 5034 00	Tab	Patte	@
19	409 2045 00	Housing Tab	Logement Raccord	@
20	409 2042 00	Housing Tab	Logement Raccord	@
21	228 7610 45	Flanged Nut M6	Écrou à épaulement M6	1



® *MARQUES DE COMMERCE DE BOMBARDIER INC.
TOUS DROITS RÉSERVÉS © 1995 BOMBARDIER INC.
LITHOGRAPHIÉ AU CANADA

® *TRADEMARKS OF BOMBARDIER INC.
ALL RIGHTS RESERVED © 1995 BOMBARDIER INC.
LITHO'D IN CANADA